



MANUAL

Installation

Operation

Maintenance

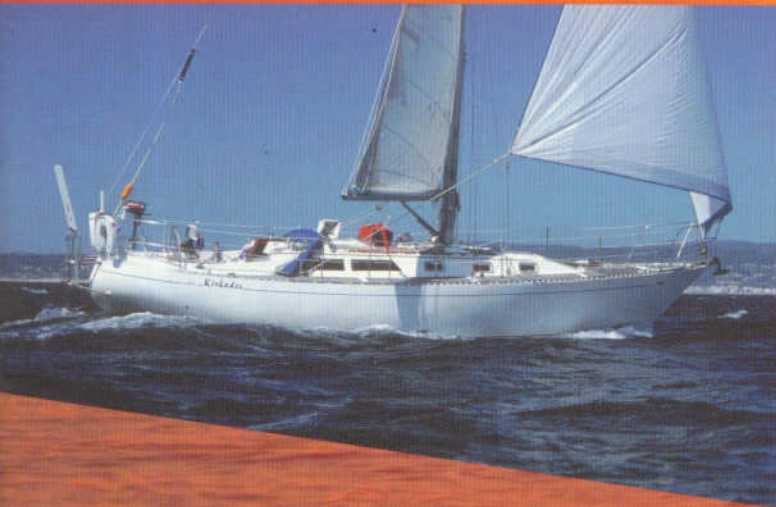

INTRODUCTION

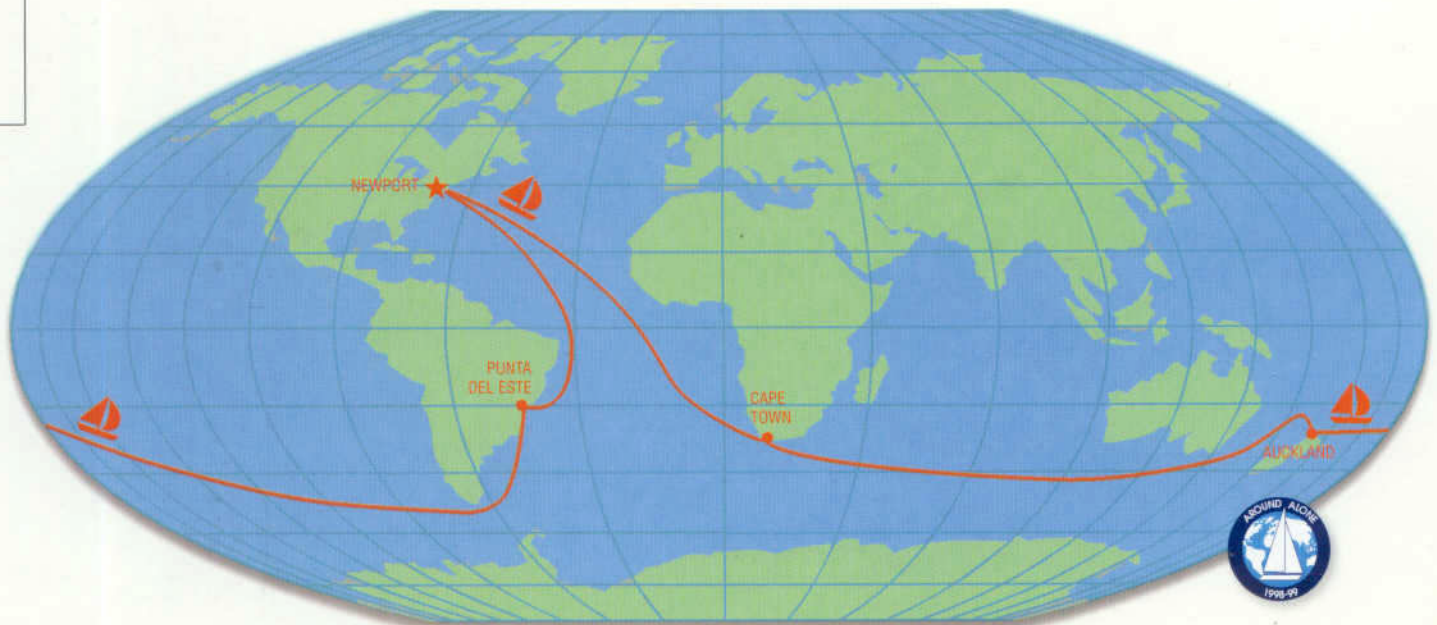

This third edition of the MONITOR Manual was published just in time for year 2000. The first MONITOR was made in 1975 and the first decent manual was published in 1982. To the untrained eye a MONITOR that is more than twenty five years old looks just about the same as a current MONITOR. However, the MONITOR's successful participation in three consecutive BOC single-handed, around the world races, and one AROUND ALONE, has given Scanmar unequalled testing possibilities for the gear, and we think we have put the

experience to good use. Our BOC/AROUND ALONE experiences, together with the feedback from thousands of regular cruising sailors who have crossed the oceans for two and a half decades, have resulted in many improvements and design changes. Today we feel that we are building a truly perfected product.

The real challenge in the redesign and modification process has been to produce new parts and designs that would fit all the older MONITORS that are still sailing the Seven Seas. We have succeeded in this objective, but,

to make sure that we always deliver compatible parts, the following message is important:

*When contacting the factory for spare parts or advice for your MONITOR always include the **SERIAL NUMBER**. You will find it on the main frame crossbar between the attachment of the two upper mounting tubes.*

Meanwhile, we wish you great cruising and fair winds.

Sincerely yours,

Hans Bernwall
President
SCANMAR INTERNATIONAL

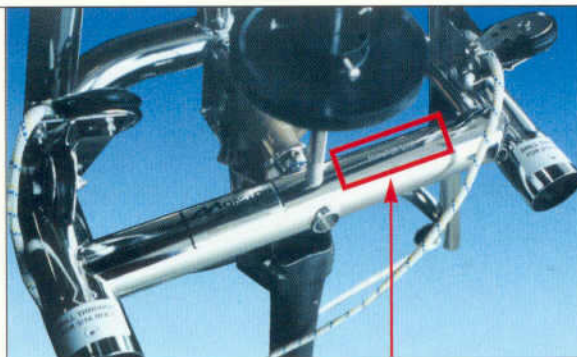

Location of serial number on the MONITOR.



ADDENDA FOR MONITOR MANUAL - November 2005

BEFORE BEGINNING YOUR MONITOR INSTALLATION -

READ THE INSTALLATION PROCEDURE COMPLETELY THROUGH -
IF YOU HAVE ANY QUESTIONS, CALL SCANMAR BEFORE BEGINNING!

NOTE THAT THE MANUAL MOUNTING INSTRUCTIONS ARE FOR A BASIC MOUNT.
**MOUNTING BRACKET LOCATION DIMENSIONS AND INSTRUCTIONS SPECIFIC TO
YOUR BOAT WILL BE FOUND ON YOUR MOUNTING DRAWING. THEY TAKE
PRECEDENCE OVER THE BASIC MOUNTING DIMENSIONS!**

THE MONITOR AIRVANES

Both the large and small airvanes are now made of 8mm Lexan Thermoclear, reinforced with plastic rod inserts. They are not affected by dampness and are warp-free. The airvane sizes once were called 'standard' (the small one) and 'light-air' (the large one). The larger airvane will give a better signal to the Monitor when you are sailing in light winds, and also when it is fairly breezy and you are sailing downwind or on a reach. In those conditions the apparent wind is light and the larger airvane will do a better job. Do not be afraid to use it in strong winds. Some sailors use one or the other for given conditions, which vary from boat to boat. Experiment - see what's best for your boat. You may find that you use the larger vane over 80% of the time!

LENGTH OF SAFETY TUBE (Paragraph 3.2.3)

The standard safety tube length is 14" - the manual misprints the length as 12". The safety tubes come in lengths of 12"(-2), 14"(standard), 16"(+2), 18"(+4), and 20"(+6). The appropriate safety tubes for your mount will be supplied.

STANDARD INSTALLATION (Paragraph 3.3.1, (17))

The first paragraph should begin with "Insert the two long spacer tubes...." instead of "..the two short spacer tubes.."



432 South 1st Street, Point Richmond, CA 94804 USA
Tel: 510 215-2010 • Fax: 510 215-5005
email: scanmar@selfsteer.com • www.selfsteer.com
Call Toll Free: 1-888 WINDVANE (946-3826)
© 2001 Scanmar International. All rights reserved



TABLE OF CONTENTS

1 WELCOME ABOARD

2 DESCRIPTION OF THE MONITOR

Servo-pendulum Principle – HOW THE MONITOR WORKS	2.1
The Airvane	2.2
Actuator Shaft and Gear Linkage	2.3
The Servo-pendulum	2.4
Lines and Blocks	2.5
Vane Frame and Hull Attachments	2.6

3 INSTALLING THE MONITOR

Attaching the Frame	3.1
Important alignments	3.1.1
Installing afloat or hauled	3.1.2
Reinforcement of transom	3.1.3
Determining the Proper Height of Installation	3.2
Factory assistance	3.2.1
Height from waterline	3.2.2
Length of safety tube	3.2.3
Importance of the boat's wake	3.2.4
Name boards and swim ladders	3.2.5
Standard Frame Installation Checklist	3.3
Standard installation (straight upper tubes)	3.3.1
Bent upper tubes	3.3.2
Diagonal tubes	3.3.3
Non-standard Frame Attachments	3.4
Installing the Pendulum Sheet Lines	3.5
General Hints – pendulum lines	3.5.1
Tiller installation	3.5.2
Wheel installation	3.5.3
Pendulum lines to blocks at the bottom of legs	3.5.4
Installing the Airvane Course Control Line	3.6

4

SAILING WITH THE MONITOR

Becoming a Vane Sailor	4.1
Standard Operating Procedure Checklist	4.2
Ready the gear	4.2.1
Assume the desired heading	4.2.2
Balance the boat for the desired point of sail	4.2.3
Trim the airvane and engage the vane gear	4.2.4
Fine tune for optimum course holding	4.2.5
Your First Sail With the MONITOR	4.3
Balancing for Self-Steering	4.4
Problem boats and easy ones	4.4.1
Light airs	4.4.2
Running	4.4.3
Reaching	4.4.4
Hard to weather	4.4.5
Give it a chance	4.4.6
Useful Hints to Get the Most out of Your Vane	4.5
The light air/high performance airvane	4.5.1
The downwind problem	4.5.2
Friction and binding in the MONITOR	4.5.3
Friction in the yacht's steering system	4.5.4
Friction in the pendulum lines	4.5.5
The autopilot friction	4.5.6
Autopilot Hook up to the MONITOR	4.6

5

MAINTENANCE AND PROBLEM SOLVING

Appearance	5.1
Regular Maintenance	5.2
Preventing Problems and Damage	5.3
Collision avoidance – removing the servo-paddle	5.3.1
Remove the airvane	5.3.2
Safety line/pull-up line on the water paddle	5.3.3
Hard weather	5.3.4
Trouble-shooting Guide	5.4
Faulty installation of the MONITOR	5.4.1
Faulty operation of the MONITOR	5.4.2
The boat's steering system has excessive friction	5.4.3
The MONITOR is faulty and needs repair or adjustment	5.4.4
Boat is sailed incorrectly	5.4.5
MONITOR as Emergency Rudder – MRUD	5.5

6

MAKING REPAIRS

Repair Overview	6.1
Repairing the Airvane Pivoting Assembly	6.2
Disassembling the airvane control assembly	6.2.1
Disconnecting the actuator shaft	6.2.2
Correct spacing of the airvane yoke	6.2.3
Realigning the airvane yoke	6.2.4
Installing bearing cups	6.2.5
Assembling the airvane bearings	6.2.6
Remounting the airvane base and airvane pilot shaft	6.2.7
Actuator Shaft and Gears	6.3
Adjusting the length of actuator shaft	6.3.1
Adjusting the angle of the pendulum blade	6.3.2
Gear separation – proper mesh of gears	6.3.3
Changing the actuator shaft bearings and bushing	6.3.4
Replacing Gears and Pendulum Parts	6.4
Disassembling the gears and the pendulum	6.4.1
Remounting the pendulum and pinion gear in the frame	6.4.2
Replacing the ring gear	6.4.3
Replacing the watervane pivot shaft	6.4.4
Replacing the pendulum strut	6.4.5
The Hinge and Latch Assembly	6.5
Latch adjustment	6.5.1
Hinge adjustment	6.5.2
Replacing the Safety Tube	6.6
Making Your Own Airvane	6.7

7

MRUD— The MONITOR Emergency Rudder Conversion Kit *(optional equipment)*

Instructions	7.1
Mounting and Operation of the MRUD at Sea	7.2
Mounting the MRUD	7.2.1
Operating with the MRUD	7.2.2

8

WARRANTY

Warranty	8.1
Warranty Photographs	8.2
A Word of Caution	8.3

Welcome to the ranks of MONITOR sailors. We hope you will be as satisfied with the MONITOR as we are. The MONITOR is built to give you years of excellent performance and to take the kind of punishment the sea sometimes delivers.

Many yachtsmen are still unfamiliar with windvane self-steering gears. They view vane gears as oddities used by single-handed race heroes and circumnavigators. The truth is that a good vane gear, such as the MONITOR, is a useful piece of equipment even on short passages of no more than an hour or so. Once the freedom of sailing with the MONITOR has been experienced, this will be fully appreciated.

In order to enjoy the experience of self-steering, the vane gear must, of course, work. Unfortunately, windvane self-steering is not a push button

phenomenon. Knowing how to sail and how to balance your boat on different points of sail is necessary to get the most from the gear. Even experienced ocean racing sailors have confessed that vane sailing has taught them some things they did not know about balancing and trimming a boat. Windvane self-steering is an extension of sailing itself.

This is no excuse for inferior performance. The MONITOR is built with absolutely no corners cut and the greatest consideration for performance and durability.

This extensive manual is necessary because windvane self-steering requires you to learn about it before you become a perfect operator. Proper installation and proper operation are essential, and we hope the number of pages in this manual will not keep you from reading it.

HINTS FOR USING THIS MANUAL:

Important information and tips about your MONITOR will be HIGHLIGHTED in **bold, italic type**. References to key parts are followed by a number, which refers to the official "**MONITOR Diagram and Part List**". This is a separate fold-out, inserted in the pocket of the back cover of this Manual. This Parts Diagram is printed on water and tear resistant paper.



To see a boat being steered perfectly by a MONITOR will amaze the most experienced sailors the first time. It might actually be a bit intimidating.

DESCRIPTION OF THE MONITOR

Servo-pendulum Principle – HOW THE MONITOR WORKS 2.1

The MONITOR is a servo-pendulum type self-steering gear. This vane design was first developed by Colonel "Blondie" Hasler for the early single-handed transatlantic races.

The signal from an airvane is always comparatively weak and usually not, in itself, powerful enough to correct the course of the boat. The intermediate mechanism of the servo-pendulum provides enormous amplification of the force of the airvane's signal. It uses the boat's own speed through the water as a power source.

The MONITOR consists of: (A) an AIRVANE which registers whether the boat is on or off a desired heading; (B) a CONNECTING ROD and GEAR LINKAGE through which the signals from the airvane control the angle of the blade of the servo-paddle; and (C) the SERVO-PADDLE which is positioned in the water.

When the boat wanders off course, the airvane gives a signal, which rotates the blade of the servo-paddle, causing the blade to be hit on its side by water rushing past. The water forces the paddle to swing to the side and a considerable leverage is created through the pendulum shaft.

The servo-paddle is connected through (D) LINES and BLOCKS to the tiller or wheel of the boat, and the resulting movement of the boat's rudder returns the boat back on course.

The airvane, pendulum, and control lines are held together in the (E) VANE FRAME, which is installed on the stern of the yacht.

Illustration of an early MONITOR. Vintage 1975

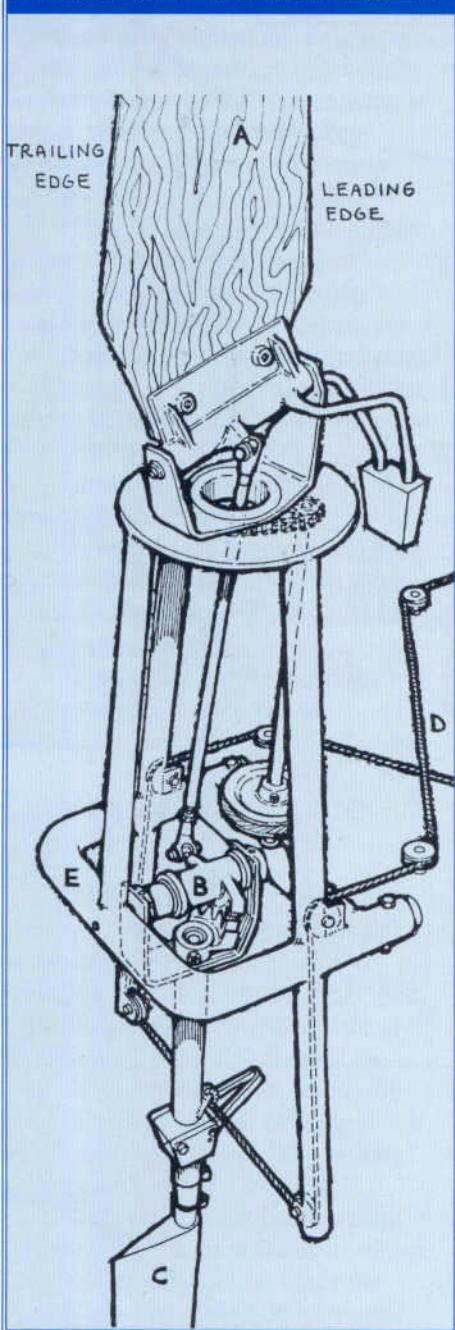

HOW THE MONITOR WORKS 2.1

With the boat trim and on course, and the airvane/counter weight into the wind, the airvane stands upright...

and the linkage and gears are centered.

In this attitude, the pendulum watervane is aligned with the hull...

and the tiller or wheel and rudder are in the on-course position.

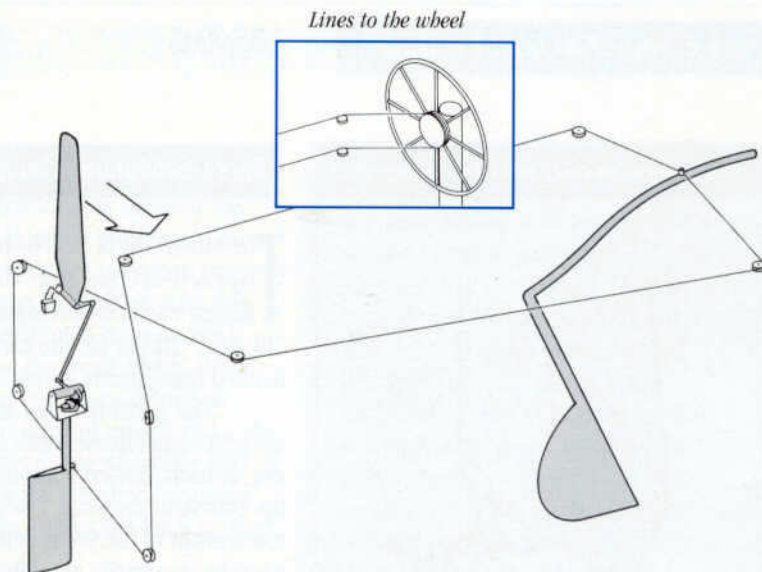

As the boat yaws to port, the apparent wind, as sensed by the airvane, changes, pushing the airvane aft.

The movement of the airvane rotates the master gear slightly...

which rotates the pendulum watervane in the direction the rudder must turn. Water pressure against the pendulum swings the watervane to port, pulling the port control sheet...

which pulls the tiller to port causing the boat to move to starboard and back on course.

As the watervane swings out of its neutral position to make the correction, the mesh of the gears rotates it back toward alignment with the hull. The force of the water on the watervane reduces progressively and the course correction is thus smooth and with no apparent over-correction.

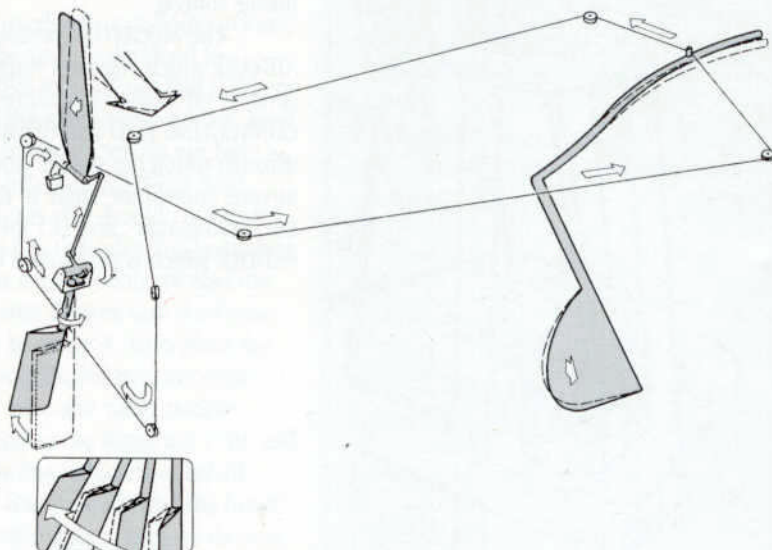

If the boat yaws to starboard, the opposite situation occurs. the airvane "reads" a change in apparent wind...

depressing the linkage and rotating the master gear.

The master gear turns the pendulum to starboard, the direction the boat's rudder must turn, causing the watervane to swing in that direction...

pulling the starboard control sheet...

which pulls the tiller to starboard and moves the boat to port and back on course.

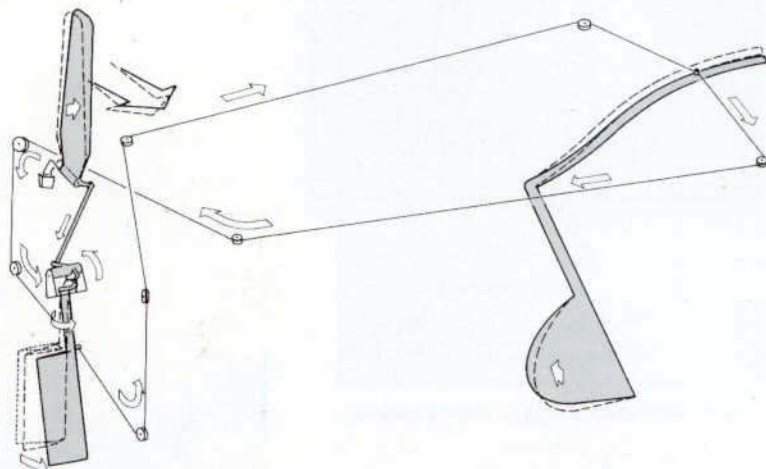

The Airvane 2.2.

The MONITOR is delivered with two airvanes, the standard and the much larger light airvane. (See paragraph 4.5.1 for details about the light airvane.)



The standard airvane (1) of the MONITOR is made of 4 mm, 4-ply of the finest Finnish birch plywood. This material may not be ideal from the standpoint of aerodynamic shape and weight, but its durability and ease of replacement in remote areas outweigh this.

The airvane pivots around an inclined horizontal axis, rather than around a vertical axis like the flag-type vanes seen on some other gears. The horizontally pivoting vane is more efficient under all circumstances. Tilting the axis slightly away from straight horizontal causes the airvane to gradually feather into the wind as it flips to the side. This provides a feedback system, which prevents over-correcting.

The horizontally pivoting vane should be adjusted with its leading edge facing into the wind when the boat is on the desired heading. The leading edge is the edge on the side of the lead counterweight (the high side of the tilted horizontal axis). When this edge is turned into the wind, the equal wind pressure on either side of the vane blade will keep the vane upright. If the boat wanders off course, the wind hits only one side of the airvane, causing it to pivot.

It is important to remember which edge is the leading edge and which is the trailing one. It is possible to bring the vane upright by turning the back edge into the wind, but this will produce completely reversed reactions in the vane gear, taking the boat further off course instead of bringing it back to the desired heading. To avoid mistakes we have a label on the airvane:

THIS SIDE TOWARDS LEAD WEIGHT WHICH POINTS INTO THE WIND. STORE WHEN NOT IN USE.

The airvane is adjusted and kept in position by a course control line, which turns the airvane through a pulley (79), chain (18) and sprocket drive (40). There is a small hole close to the label for a safety line. We suggest that you tie or clip it to the counterweight tube (5).

Again, the airvane has very little power even under the best of conditions. To get maximum performance, the MONITOR airvane pivots on specially made ball bearings consisting of Delrin balls in stainless steel races.

The counterweight under the airvane balances the vane. Ideally, it should barely be able to keep the vane upright when there is no wind. The airvane must not be top heavy. An airvane which is too heavy will not work at all in light air because the airvane will send faulty signals. The factory airvanes are carefully balanced. If you have to make a replacement vane using material available in a foreign port, be very careful to make a vane that is as large as possible but not too heavy. (See paragraph 6.7.)

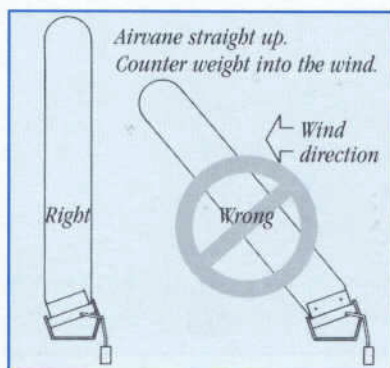

Actuator Shaft & Gear Linkage 2.3

The pivoting of the airvane is transferred through an actuator shaft (57) and a bronze master gear set (36 & 37) into a rotation of the watervane paddle (61). This linkage in the MONITOR is strong, direct, and relieved of friction through Delrin bearings (54) in the connecting rod and through Delrin roller bearings (31) in the pinion gear (36) and the pendulum strut (26). The strength and freedom from slop and friction in the airvane-to-pendulum linkage is one important key to the superior performance of the MONITOR.

Through the design of the bronze gear set, a second feedback is provided, as the gear will gradually neutralize the rotation angle of the watervane paddle (61) when this blade swings to the side. Again, the feedback serves to dampen any over-steering tendencies.

When the airvane is in the upright, on-course position, the servo-paddle should be lined up exactly fore and aft.

This adjustment is initially made at the MONITOR factory. If, for some reason, it has to be repeated, it is performed by releasing the locknut (56) at the lower end of the connecting rod (57) and by adjusting the length of the rod. (See paragraph 6.2.2.)

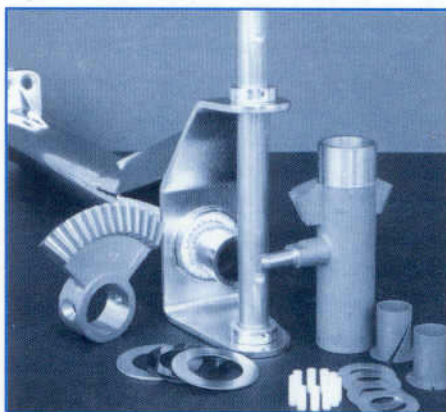
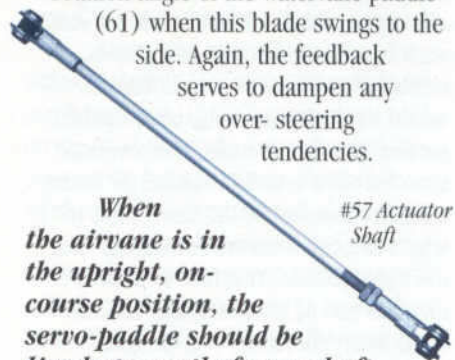

The Servo-pendulum 2.4

The MONITOR pendulum is hinged in the frame on a solid $\frac{3}{8}$ " stainless steel watervane support shaft (33). The upper half consists of an outside strut (26) with Delrin roller bearings (31) at each end for friction-free rotation of the pivot shaft (43) inside it.

Below the strut, the pendulum shaft ends in a $\frac{3}{8}$ "-thick hinge block (43), which is part of the latch mechanism (47) that allows the water paddle (61) to be easily taken out of the water. The design also allows the water paddle to be easily put back into the water and locked automatically in this position.

The MONITOR latch is self-energizing. It engages harder under increased pressure. The latch is designed not to open in case of an overload, since such conditions also could occur in extreme hard weather conditions. It would be disastrous if the latch opened surfing down a big wave. True overload situations like a violent broach or hitting a log are handled by the safety tube (67), which is located between the hinge and the water paddle. This tube is weaker than the rest of the pendulum and can bend in any direction. It is designed to buckle upon a severe impact that would otherwise cause more extensive damage to the gear.

Below the safety tube is the watervane (61) or the servo-paddle itself. This paddle is the powerhouse of the MONITOR.

The MONITOR paddle has been given a NACA high-lift profile, and its leading edge has been moved forward of the center of rotation to semi-balance the blade. This allows the airvane to rotate the paddle with a minimum of force, improving the light air performance of the gear.

The paddle has a stainless steel skin welded to a stainless inside shaft. Its hollow part has been filled with polyurethane, closed cell foam. The end result is an extremely strong and rigid servo-paddle.

Lines and Blocks 2.5

The MONITOR is delivered with 35'–50' of $\frac{1}{4}$ " custom-made Spectra line. The inside core is straight Spectra to minimize stretch, and the outside is braided polyester to resist wear and chafing. After the ropes leave the main frame, you will probably use two to four blocks. The type of blocks varies from one installation to another. Consult a block catalog and/or your local yacht chandler. We recommend good low friction bearing blocks with approximately 2" diameter sheaves. Good blocks will minimize friction and improve performance at low wind and boat speed. This is not the place to try to economize. As will be discussed later, paying some extra attention to the installation of the pendulum sheet lines can often improve the performance of the MONITOR.

Vane Frame & Hull Attachments 2.6

The MONITOR vane frame (58) forms a very strong, integrated unit. The pendulum lines are normally led through the "legs" of the frame. The pendulum lines are attached 18" away from the pivoting point. This gives the MONITOR a powerful one-to-one purchase. Other vane frames with shorter pendulum arms routinely have to have a complicated block arrangement in order to achieve the required line movement when the boat is wheel steered. The MONITOR method offers simplicity and great strength.

The frame is attached to the hull by means of two larger upper tubes (89), which slide into sockets on the frame, and two lower tubes (88), which attach to the bottom of the frame legs through end fittings (82). The tubes are fitted with U-shaped brackets (83) at their ends for through bolting to the hull. Each bracket is attached with two bolts. The MONITOR four-point attachment is universally adaptable to all kinds of stern configurations. It is the easiest and strongest attachment of any vane gear of this kind, and the four attachment points distribute the load on the boat. This strength makes possible the use of the optional Emergency Rudder (MRUD) discussed later in this Manual. (See paragraph 7.)

Same-side diagonal tubes are often added on boats requiring extra-long mounting tubes. Boats with outboard rudders or reverse transom boats with extreme rake are such boats. The diagonals will form triangulation and the mounting will be extremely strong. The diagonal struts are normally fastened to the existing bolts on the U-brackets. No extra drilling should be necessary.

If the MONITOR has to be removed, only the four bolts holding the mounting tubes to the U-shaped brackets have to be removed. The MONITOR mounting system also offers another a bonus feature – it will also serve as an emergency swim ladder. As long as you can get to the back of the boat, you should be able to use the water paddle and the mounting system to climb back on board.

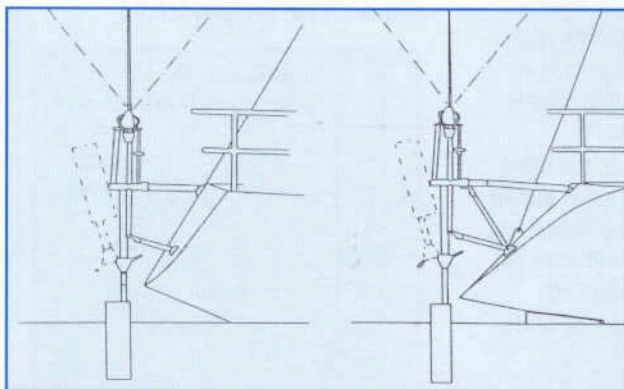

Regular

Diagonals from lower hull brackets



Diagonals from bottom of legs

Attaching the Frame 3.1

Important alignments 3.1.1

Generally the MONITOR is attached to the stern with two upper and two lower mounting tubes. These are bolted to the boat by means of universal U-shaped brackets (83), which will fit any angle or curvature of the hull when rotated. Each bracket has two 5/16" holes for stainless steel bolts, which will be through bolted.



The gear has to be mounted on the centerline of the stern, vertically and horizontally. The vane gear should not be tilting forward, aft, or to one side.

Off-center mounting is not recommended. It would possibly work going dead down wind when the boat is not heeled. When reaching or going against the wind the boat is heeled and on one tack the servo-paddle would be out of the water and on the other tack it would be far too deep in the water. With the exception of multihulls, which do not heel very much, we are strongly against off-center mounting unless we are only talking about a few inches. Also see 3.2.5

Installing afloat or hauled 3.1.2

It is generally much easier to install the vane gear with the boat afloat, especially with the stern backed into a floating dock and spring lines holding the boat steady. When the boat is in the water it is floating on its lines and when you want to check the inside of the boat, after drilling a bracket hole, it is a lot easier to take a step from the dock than running up and down a ladder. Take great care not to drop vane, parts or tools into the water. Use of safety lines is recommended.

If you mount the MONITOR when hauled, make sure that you know exactly where the water line is. Mark it before taking it out of the water.

Reinforcement of transom 3.1.3

We estimate that more than 90% of the MONITOR installations are made without any strengthening of the transom – no backing plates, only the washers that we include. The reason is that the MONITOR is a servo-pendulum gear with a fairly small water paddle, which can swing to the side in an overload situation like a broach. The pendulum lines also have a little bit of give. This is quite contrary to a rigid auxiliary rudder type self-steering gear, which will experience higher loads and need transom reinforcement.



Stevens 47– MONITOR side view

As we pointed out earlier, the MONITOR distributes the load to four mounting brackets. Most of the time the brackets get located close to the corners or joints of the transom, hull or deck. This is where the boat is very strong. The weakest part would be in the middle of the transom but no attachment is used in this area with the MONITOR.

You should consider backup plates on an ultra light racer with extremely thin fiberglass or boats with a foam or honey come core. Marine plywood would be an excellent material for this reinforcement.

These guide lines have worked well in the past for MONITOR installation but it is up to the individual owner to decide if strengthening of the boat is necessary or not.

Determining the Proper Height of Installation 3.2

Factory assistance 3.2.1

All new MONITOR vane gears are delivered with custom factory designed and fabricated mounting systems together with an installation drawing for each individual boat. This valuable service is included in the price of the MONITOR and when in doubt you should contact the factory for advice. The factory has the experience and feedback from many thousands of installations.

Height from waterline 3.2.2

The vane gear should, if possible, be located so that about 6" of the top of the paddle are out of the water when the boat is stationary and loaded for cruising. This puts the main frame (58), into which the large diameter upper mounting tubes (89) are inserted, within the range of about 40"–50" (1016–1270 mm) above the water, depending of the length of the safety tube (67). The height of the freeboard of the yacht will determine if the upper tubes will be mounted on deck or on the stern.

Keep in mind that the boat may float differently when loaded for cruising (e.g. full water and fuel tanks plus supplies). As a rule of thumb, the average cruising boat will ride one inch lower for every 1000 pounds of added weight.

Length of safety tube 3.2.3

A standard 12" safety tube is delivered with most MONITORS, but boats with very low or very high freeboard at the stern may require a shorter or longer pendulum than standard. Shortening or lengthening the safety tube (67) varies the length of the MONITOR pendulum shaft. With a standard safety tube, the upper mounting tubes (89) should be located approximately 42" (1067 mm) from the waterline. Tubes sized -2", +2", +4", +6" and +8" are available from the factory to meet special design needs. No shorter tube than -2" should be used

since no room would be left for the tube to buckle in an overload situation. The standard rule of leaving 6" of the paddle blade out of the water still applies, although the frame itself will now be mounted higher or lower depending on the variance in safety tube size. For boats over 45-foot LOA, we normally design the mounting system allowing the use of a longer safety tube. The increased leverage gives more power, which often is required on the larger boats.



The Monitor factory will solve this dilemma for you and provide an installation drawing for each individual boat. Together with the manual you should have no problem to mount and use the Monitor.

	inches	mm
A. standard air vane	37	940
light air vane	45	1143
mizzen air vane	26	660
B.	23½	597
C. varies with length of safety tube		
Standard length	42	1067
- 2	40	1016
+ 2	44	1118
+ 4	46	1168
+ 6	48	1219
+ 8	50	1270
D. watervane with 6" out of the water	18	457
E. center of upper mounting tubes	15	381
F. center of leg to center of leg - at bottom	23½	597

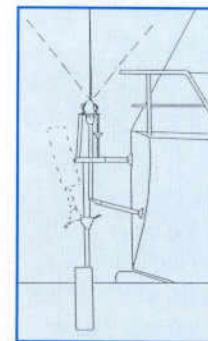
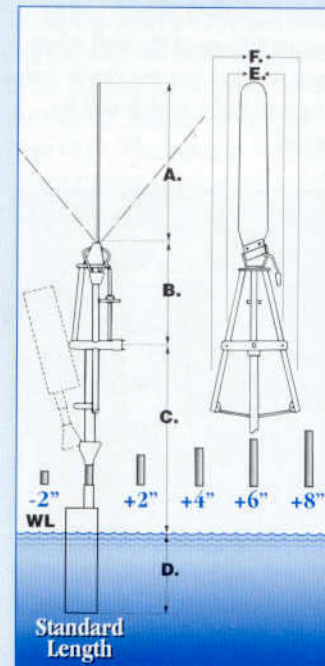

Boat with high freeboard uses a +6 Safty Tube

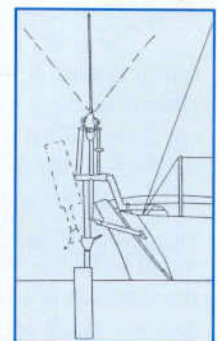

Boat with low freeboard uses a -2 Safty Tube

Importance of the boat's wake 3.2.4

The level indicated above is a rule of thumb, which is subject to much variation. The proper location of the vane gear, up or down, should be determined by the dynamic waterline which is created when the boat is moving at different speeds on different points of sail.

Each boat is different, and its owner best knows its characteristics. However, with the experience from years of installations and proper records we feel that our recommendation and installation drawing in general can be considered correct if proper measurements have been given to us in the first place. However, here are some additional guidelines to be used in determining proper mounting height.

The paddle at the end of the servo-pendulum is the power source of the vane gear. As long as a part of the paddle is immersed in the wake behind the boat, the vane gear will operate as designed. It is very unlikely that the servo-paddle will lift out of the water occasionally, but it could possibly happen to a yacht with very long overhangs in choppy seas or a boat with an extremely wide transom. This will not seriously interfere with the efficiency of the gear. However, if the paddle remains out of the water for long periods, the performance of the vane will be affected.

Nothing is gained by mounting the vane gear so low that not only the paddle but also the pendulum shaft is covered by the wake. The strains on the welds and mountings multiply without any improvement in the functioning of the gear.

From this it follows that ***the MONITOR should be mounted so that the water paddle is always immersed to some degree yet the pendulum shaft and hinge are immersed as little and as seldom as possible.***

Some boats have very different waterlines at the stern when they are still versus when they are moving fast. Yachts with long overhangs generally have water all the way up under the transom when sailing downwind at cruising speed. The wake can result in the water being much higher on the transom than when the

boat is still or moving slowly. Double-ended hulls tend to squat, especially going downwind, and, if the stern is fine, with little buoyancy, the wake can sometimes climb very high. In these cases, the vane gear must be mounted as high as possible while still keeping the paddle immersed, to some degree, at slower speeds and on different points of sail. This is especially important if the boat is large and fast or uses an extra long pendulum shaft, which also increases the loads on the gear.

IN SUMMARY: You are pretty safe following the factory installation drawing that we have provided. If it is a popular boat we probably have had lots of sisterships with MONITOR and the drawing is based on plenty of feedback. ***Six inches of the paddle out of the water, on a stationary boat, fully loaded, at the dock, is correct in most cases.*** Sometimes it might be a good idea to observe the wake of the boat on different points of sail and in various conditions. This could be done, for example, by using a clearly marked yardstick to assess the level of the wake. If this level varies much, there will be times when the safety tube and even the pendulum shaft are immersed to some degree. There is no cause for panic as the MONITOR is built to withstand great loads. However, there is no point in increasing these loads unnecessarily, and we have found that the tendency is always to mount the vane gear too low rather than too high.

If in doubt, always mount the MONITOR HIGHER rather than lower unless you already have the maximum +6" or +8" safety tube.

We rarely see the MONITOR mounted too high, but sometimes we see installations that are too low. If you mount the MONITOR too high, the paddle can be lowered by a longer safety tube, which we would supply. The longer tube gives your MONITOR more leverage, which yields more power.

There are too many variables to always sail with the perfect submersion of the water paddle at all times. Big crew in the cockpit or on the foredeck, upwind or down wind, full or empty fuel and water tanks, lots of supplies or no supplies are only a few factors that will influence the

waterline. Through the years we have seen a few severe mounting mistakes but it really does not seem to matter. The reason for this whole discussion about the waterline is that we are simply trying to get the mounting as correct as possible for a variety of conditions.

Two more observations:

All cruising boats seem to put more supplies and more weight on board than expected, and all boats seem to really squat under power.

Name boards & swim ladders 3.2.5

Some owners let the position of a name board or swim ladder, etc., dictate the location of the vane gear. This, definitely, is a faulty order of priorities if you intend to make serious use of your self-steering gear. The MONITOR tirelessly performs the work of several crewmembers. Its importance can only be appreciated by sailing a passage with the gear and one without it. The correct positioning of the vane is of greater importance than that of convenience and embellishment. Usually the MONITOR attachment tubes can be bent or welded so that the vane gear can be correctly mounted without disturbing name boards, ladders and even open transoms.



Ladders can often be relocated on the transom to the side of the MONITOR. A welder can easily modify a wide ladder and make it narrower. We also like to point out that, traditionally, the best location for the swim ladder has been midships. ***DO NOT let your swim ladder dictate the location of your windvane.*** Also see 3.1.1.

Standard Frame Installation Checklist 3.3

Read the ENTIRE procedure before beginning installation.

Follow the steps outlined in paragraph 3.3.1 to mount the standard vane gear. (Special instructions for MONITORS with bent upper tubes or diagonal tubes are found in paragraphs 3.3.2 and 3.3.3.)

Mark off the "completed" box after each step, then go on to the next step. The following tools are needed:

- **Variable speed** drill with $\frac{1}{4}$ " and $\frac{5}{16}$ " drill bits. We recommend the best bits available such as cobalt tipped.
- Two $\frac{1}{2}$ " (13 mm) wrenches, pliers, small wire cutter, screwdriver, mallet (or hammer & block), and tape measure. Adjustable wrenches or socket sets also come in handy.
- Suitable bedding compound (e.g. Boatlife, Sikaflex or the like), masking tape, marking pen and pencil.

Standard installation 3.3.1 (straight upper tubes)

(1) Locate the centerline of the boat on the stern and measure $7\frac{1}{2}$ " athwartships, making a reference mark that will be used to center your frame. The backstay is usually a good reference point since it is located on the centerline of the boat.

Completed

(2) Put masking tape on the hull brackets (83.2 and 83.4) to prevent scarring the hull. Insert the large mounting tubes (89) all the way to the bottom of the sockets of the main frame (58). Using a marker or tape, mark the tubes when they are all the way in.

Completed

(3) Use two ropes tied to your pulpit and to each side of the frame to support the vane gear at the right level above the water. On ketches you might hang the MONITOR from the mizzen. On single masted boats, you could possibly rig up a spinnaker boom to protrude behind the boat or use the main halyard. Center the tubes on the marks made previously, then

rotate the tubes until the upper brackets (83.2) fit flush against the hull or deck. **Check inside the hull** where the bracket bolts will be through bolted to make sure that there are no problems with the location. **MAKE SURE THAT YOU ARE SATISFIED WITH THE LOCATION – once you drill the first hole you are committed to both height and sideways mounting.**

Use the bracket hole as a template and drill one $\frac{5}{16}$ " hole. You should first drill the hole that is not covered by the tube. Insert a bolt (84.4) in the hole, and drill the second hole for the bracket. Bolt bracket on ONE SIDE of the hull. (Nuts should only be loosely tightened at this point to allow further adjustment.)

Completed



New U-shaped mounting brackets with smaller foot print and only two holes per bracket

(4) Level the gear athwartships making sure that it is not tilting to one side. The easiest way to do this is to lie down on the dock and align the aft support tube of the MONITOR with the mast on the boat. Drill one $\frac{5}{16}$ " hole and attach the bracket on opposite side with one bolt. (Again, drill the hole that is not covered by the tube first.) Secure the location with a bolt and drill the second hole.

Completed

(5) With both upper tubes temporarily attached, use the ropes to level the MONITOR in a fore-aft direction. When gear is level, rotate the airvane 360 degrees. Check at different settings around the full circle for clearance of the airvane and counterweight relative to the backstay and pulpit or other obstacles. Be sure to flip the vane as far as possible to each side when checking the clearance around the full circle.

Completed

(6) **Try to mount the vane as close to the hull as possible while maintaining clearance for the airvane counterweight and pendulum.** The distance between the MONITOR paddle (61) and the edge of the main rudder should be at least 12", in general. Establish the shortest possible length of the upper mounting tubes (89) which still give clearance. If clearance is excessive, remove the gear and cut tubes accordingly with a hack saw. Do not hesitate to cut the tubes. With a good hacksaw blade it is very easy to cut the stainless steel tubing right on the dock. The closer mounting will look better and it will also be easier to service the MONITOR and to dock the boat.

Completed

(7) After cutting, reinsert the mounting tubes and make a final check for clearance and alignment. If you have cut one tube longer than the other, the vane will mount crooked. When the upper tubes are completely in the sockets, mark them again with masking tape or a marker at the edge of the socket to make sure that they do not slide out without your noticing it.

Completed

(8) Attach end fittings (82) to the bottom of the "legs" of the frame with bolts (86.1). Do not tighten the bolts very hard at this time. Then insert the lower tubes (88) in the end fittings. The telescoping end fittings for the lower mounting tubes permit easy adjustment for the vertical installation of the main frame. The ability to rotate the lower mounting tube inside the end fitting also makes it easy to adjust the U-shaped brackets (83.4) to the curvature of the transom.

If we do not have exact measurements or records, our general policy is to deliver all mounting tubes on the long side, rather than delivering the tubes without any margin for error. It is very easy to shorten the thin wall tubes with a fresh hacksaw. Make sure that the lower mounting tubes are inserted at

Standard Frame Installation Checklist 3.3 (continued)

least 1" past the pilot hole in the end fitting. Use a marking pen and masking tape to show the connection and make sure that the tubes remain in the correct position. Taking the vane frame as a starting point, **the lower tubes should slope down about 10–15 degrees from a horizontal line from the vane and spread out about 10–15 degrees from a straight line to the hull.**

The installation drawing for a boat with open transom, swim steps or swim platform often specify an angle different than 10–15 degrees. In those cases the installation drawing will take precedence. **IF IN DOUBT, contact the factory!**

Completed

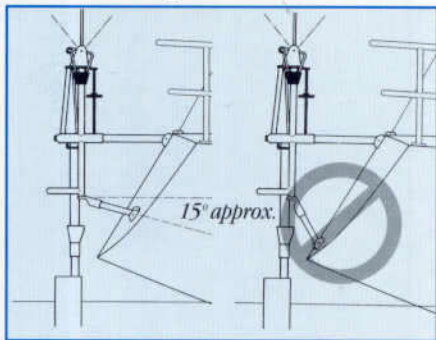

RIGHT WRONG

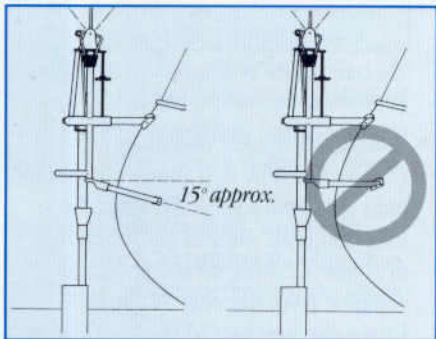

RIGHT WRONG

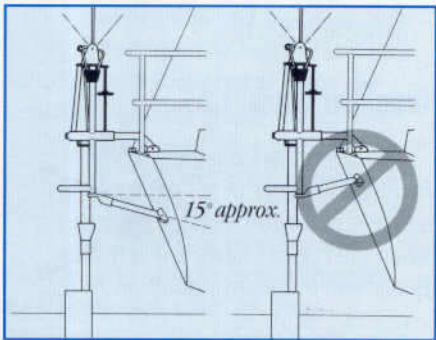

RIGHT WRONG

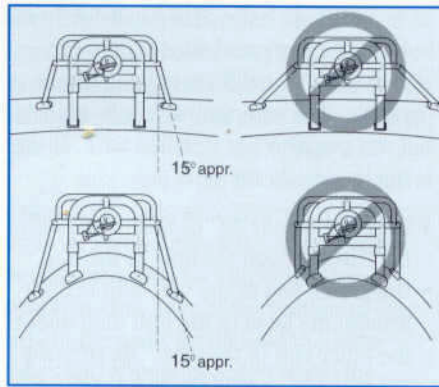

RIGHT WRONG

(9) With the MONITOR level fore and aft, rotate the lower tubes (88) until brackets (83.4) are flat against the hull. The angle of the end fittings (82) can easily be bent up or down if minor changes are necessary. Just secure the end fitting with the bolt to the bottom of the leg and bend by hand.

Check where the lower tubes should attach to the hull, measure length, and cut the tubes if necessary. Before you cut, check inside again to be sure that there are no obstacles to through bolting in the area where the lower brackets will be attached.

Completed

(10) Locate the hole in the lower bracket that is not covered by the tube. Drill a 3/8" hole through the stern using the bracket as template. Insert the bolt and fasten. Mark the location of the bracket. Remove tube from bracket and drill second hole. Repeat the procedure on the opposite side.

Completed

(11) Check again that the MONITOR is level in all directions and that both upper and lower brackets are drilled and bolted. At this point it is not necessary to tighten the nuts hard. You only want to make sure that they stay in place while you once again check that the holes to the end fittings of the lower tubes are properly marked and taped.

Completed

(12) Remove all bolts from the upper brackets (83.2). Loosen the ropes that hold the vane gear and lean it backwards so you can get to the underside of the brackets. The vane gear is now hanging on the ropes and the lower tubes. Remove the masking tape and apply suitable bedding compound to the underside of the brackets. Reattach the upper mountings with all the bracket bolts and washers.

Completed

(13) Tighten up on the ropes and then unbolt the lower brackets (83.4). Tighten further on the ropes to bring the lower brackets clear of the hull. Remove masking tape, apply bedding compound, and reattach with all bracket bolts and washers.

Completed

(14) Check leveling again. With lower tube end fittings loose, fine adjustments can be made. Also, the upper tubes can be moved slightly in their sockets. Once satisfied, tighten all bracket bolts to the boat.

Completed

(15) After final leveling, locate the pilot hole on top of and 3/4" from the edge of the main frame sockets. Use the pilot hole to start the drill. Drill a 3/16" hole on each side through both the socket and the upper mounting tube inserted into it.

Drilling through stainless is easy if you do it right. **You should use the absolutely SLOWEST possible speed.** The slower you can run, the better your variable speed drill will cut. **Put lots of weight on the drill and DO NOT USE DULL BITS. Use oil to improve the cutting.** Dull bits and high speed will not cut, but will work-harden the stainless making it extremely tough to get through. Take care not to upset the leveling by leaning too hard on the frame when drilling.

Completed

Standard Frame Installation Checklist 3.3 (continued)

(16) Loosen the ropes again and make the vane frame slide back in order to bring the upper tubes out of their sockets.

Completed

(17) Insert the two short spacer compression tubes (85.1) into the upper mounting tubes and align spacers with the $\frac{5}{16}$ " holes. Use a fast drying bedding compound or sealant to hold both ends of the spacer tubes in place. This will prevent the loss of these spacers if you remove the MONITOR from your boat in the future and have forgotten about them. The compression tubes will prevent the tubes from collapsing when the bolts are tightened.

Completed

(18) When the frame is in position, insert $\frac{5}{16}$ " bolts through sockets, tubes, and spacers. Tighten bolts with lock washers and nuts on the underside of frame.

Completed

(19) It is now time to secure the lower tubes to the end fittings. Insure that the vane is still vertical. Using the predrilled $\frac{1}{4}$ " hole in the end fitting (82) as a starter hole, drill $\frac{5}{16}$ " holes from both sides through the lower mounting tube (88). You might prefer to take the tube and end fitting off and do the drilling on the dock. Repeat the procedure on the other side. Insert a compression tube (85.2) in the end of each mounting tube that goes into the end fitting and secure them with fast drying sealant. Insert $\frac{5}{16}$ " bolts and secure with lock washers and nuts.

Completed

(20) Make final check of alignment and tightness of all bolts. You might consider applying Locktite on the mounting bolts, especially the bolts at the bottom of the legs. These bolts (86.1) hold the end fittings for the lower mounting tubes. The enclosed safety wire should be used

to secure these bolts. The heads of these bolts have been pre-drilled. There are also two additional bolts in your spare parts kit. The wire that we use is Monel but you can also use stainless wire. Here is one way to do it:

- Start with about 20" of wire. Put half of the wire through the hole in the bolt.
- Grasp one end of the wire and bend it around the head of the bolt then under the other end of the wire. Be sure the wire is tight around the head.
- Twist the wire a minimum of 10 times to make a nice "pigtail" and cut off the excess. Then wrap the wire around the MONITOR leg or end fitting. Bend the

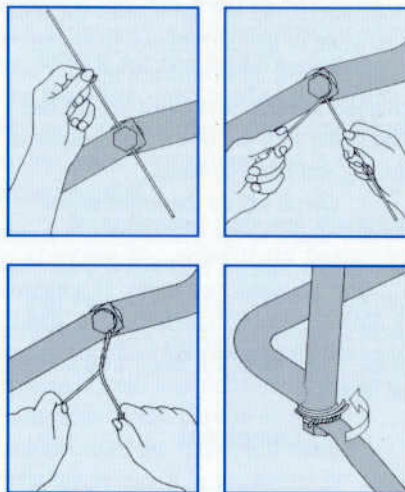

ends and place them so you cannot cut yourself or puncture your inflatable if it bumps the MONITOR.

Completed

Congratulations, your frame installation is done! You are now ready to link your MONITOR to your tiller or wheel. (See paragraph 3.5.)

Bent upper tubes 3.3.2

With straight upper tubes you simply rotate the tubes till the angle of the bracket fits the angle of the transom. Bent upper tubes require one more step as it is not possible to install the U-

shaped brackets at the factory. We do not know the angle that will give it a flush fit, and the holes for the brackets have to be done at the installation, as follows:

- Insert the upper tubes (89) in the frame (58) and place the MONITOR correctly with the help of lines, as explained earlier. Check if the vane gear can be brought closer to the boat and still have sufficient clearance for both airvane and counterweight. If this is possible you should shorten each tube equally. Check the position again at the proper vertical level and let the upper mounting tubes touch the boat in the location where they should be bolted to the bracket.

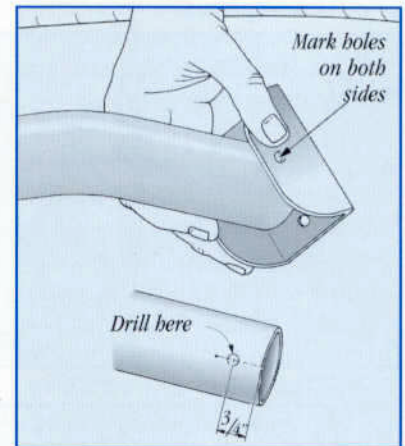

The holes for the bent upper tubes have to be drilled at the installation.

- Hold the U-shaped mounting bracket (83) to the tube and rotate the bracket until you have a flush fit. Mark the holes on both sides of the tubes and drill one $\frac{5}{16}$ " hole on either side $\frac{3}{4}$ " distance from the edge of the tube. Fasten the brackets to the boat and the tubes to the bracket as explained in paragraph 3.3.1.

Diagonal tubes 3.3.3

Sometimes diagonal tubes are included in order to get the necessary stiffness in the installation, especially when the regular tubes are very long. Boats with outboard rudder or severe

rake on the transom are typical boats that need diagonal tubes.

When it is impossible to follow the standard rule for the lower tubes (10–15 degrees out and 10–15 degrees down), we also use diagonal tubes, which will make the installation very rigid. The diagonal tubes are always on the same side. Do not attempt to cross them from starboard to port and vice versa. The diagonal tubes are attached to existing bolts and no extra drilling should be necessary. They can start at the bottom of the legs on the MONITOR and go to the upper tube mounting bracket but they can also start at the main frame and go down to the lower tube bracket. We normally select the method with the shortest distance. Placement of the diagonal tubes will be specified on the installation drawing for the specific boat. Also see 2.6.

On boats with open transom, the diagonal tubes often form a “V” with the open end of the “V” attached to the bolts that connect the upper mounting tubes to the main frame. The tubes are then attached to a single bracket at the bottom.



V-style diagonals

Non-Standard Frame Attachments 3.4

The procedures described in the checklist apply to standard installations. Boats with boomkins and other structures at the stern may necessitate special arrangements. We try to deliver mounting tubes and modifications to make the installation easy. Generally the procedures as outlined above still apply or they will be modified in the installation

drawings provided for the specific boat.

The finished installation should be rigid and the gear should easily be able to take the weight of a large man without twisting.

Installing the Pendulum Sheet Lines 3.5

General Hints – pendulum lines 3.5.1

Each boat has its own individual characteristics, which affect the proper installation of the pendulum lines. It is not possible to treat in detail each of the many ways which the pendulum lines can be connected to the boat's steering. Instead, we will speak in *general guidelines*.

Having pendulum lines leading into the cockpit is the most common objection to the servo-pendulum type of windvane steering. This argument seems to disappear once the windvane starts working since the helmsman's position is not very comfortable once your MONITOR is doing the steering. You will find that it is preferable to sit under the dodger if the spray is flying or maybe on the foredeck if you are running. You will also find that you can spend more time at the navigation station, in the galley or taking a nap in your bunk. Some planning and extra care can yield sheet leads that are efficient, hardly noticeable, and require a minimum of service.

Aside from neatness and unobtrusiveness, your main priority when installing the pendulum sheets should be *minimum friction, chafe and slack* combined with *maximum ease of inspection*. **The PRIORITY should be PERFORMANCE.**

Leads that include many turns and blocks negatively affect all of these aspects. **The STRAIGHTEST lead is the best.** Most experienced sailors seem to favor having the lines easily visible rather than inside the lazarette and lockers.

Fixed blocks give less slack and should be preferred, but great care has to be taken in mounting the blocks so that the leads are fair and chafe is avoided. Fixed blocks are also quieter in light air conditions.

It might be better if the blocks on either side of the tiller were mounted loosely to allow them to move to compensate for different angles of the pendulum lines. These angles are created as the tiller moves from side to side.

Excessive slack wastes the corrections of the windvane. However, **the pendulum lines SHOULD NOT be over tightened**, a very common mistake. Over tightening makes the blocks unwilling to turn and will negatively affect light air performance. The pendulum lines will also wear quicker.



Very long sheet leads are sometimes necessary with center cockpits but with our 3/4" Spectra line stretch is kept to a minimum. Our custom made Spectra rope has minimum stretch, is extremely strong and works well through blocks in a repeatable fashion.

Installing the Pendulum Sheet Lines 3.5 (continued)

After thousands of miles, the lines of even the best installations will eventually wear. It is actually an advantage of the pendulum system that most of the strain and wear are absorbed by relatively cheap and easily replaceable rope.

A good practice to avoid having to change the entire line is to **leave some extra rope at the forward end**. By slipping the line a few inches through the leads and tying a new figure eight knot at the pendulum, the chafe points are changed and you can get much longer service and actually sail all the way around the world with the same rope.

Your pendulum lines should also have a tensioning system, which is explained in paragraph 3.5.3.

In both tiller and wheel installations **it is useful to mark the pendulum lines** with tape or a dye marker against a benchmark on the boat **so that you KNOW when the pendulum is centered between the frame legs**.

If you engage the gear with the pendulum off-center, it will be unable to give proper and equal corrections on both sides of the desired course.

In order to avoid lines in the cockpit some sailors suggest hooking up the MONITOR to an emergency tiller instead of to the wheel. This type of installation seems to make sense, but in general we advise against it. The exception is when the boat has hydraulic steering. On such boats it is the only way to hook up a servo-pendulum gear since the hydraulic system normally has too many turns from left to right and there seems to be a slow slippage in these systems. If a bypass valve is installed on the hydraulic system and the MONITOR is hooked up to the emergency tiller you have an excellent system.

However, if the boat has a cable and quadrant, rack and pinion, worm gear or any other 2-3-4 turns mechanical wheel steering system, the vane gear would have to drag around this entire mechanism if you attempt to steer the boat through the emergency tiller. To test the resistance, try to move the emergency

tiller by hand when the boat is at the dock. You will probably find that you have to use a lot of force to move the tiller. This means that the windvane will have a very tough time steering unless it is very windy and the boat has considerable speed to overcome this added friction.

If the steering wheel itself is removed the flywheel effect of the wheel will disappear and it is easier to move the emergency tiller. The vane now works much better, but the steering wheel would have to be removed and stored. There would be more space in the cockpit, but most sailors would not feel comfortable with such an arrangement. However, in an emergency you can always disconnect the MONITOR at the emergency tiller and hand steer with the tiller until the danger is over or the wheel has been put back on the pedestal.

For the reasons above we, in general, prefer to hook up the MONITOR to the wheel if the boat is equipped with a mechanical wheel steering system.

Tiller installation 3.5.2

It is possible to lead the pendulum lines to the tiller **BACKWARD** in which case the MONITOR will not work at all.

The pendulum lines must be CROSSED before connecting them to the tiller. This is usually best done directly at the vane frame. The MONITOR starboard line is led to the port side of the tiller and vice versa.

When the lines leave the frame they pass two blocks that are mounted on adjustable brackets which make it easier to lead the lines so they do not chafe when they cross. Exactly where the pendulum lines should be connected to the tiller depends on the boat's characteristics. However, 20"-30" from the rudder shaft is a working rule of thumb. The blocks that lead the pendulum lines to the tiller should be mounted in the radius of the swing of the tiller. This gives the least slack as the tiller moves from side to side.

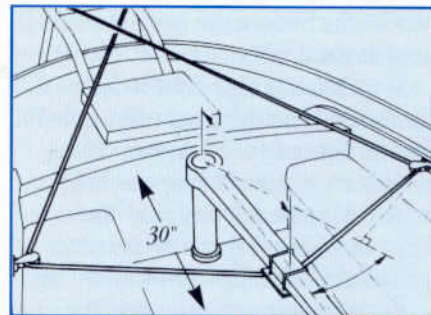

The pendulum lines are connected to the tiller by means of a stainless chain that locks into a slot on a stainless plate that is attached under the tiller. The reason for the stainless steel chain is not that it is stronger. You will find that if the boat has weather helm it is very easy to pull the chain out and move it a link or two. We have found this system to be more practical than a cam or jam cleat system.

Bend the two threaded rods to fit the shape of the tiller and attach the plate with washers and hex nuts. If the tiller is very wide, the plate should be fastened to the tiller by through bolting or long wooden screws rather than using the threaded rods. You can also modify the tiller plate by making it narrower and drilling new holes.

It is advantageous to mount the tiller plate on the underside of the tiller. When you pull the pendulum line chain out of the slot it is then hanging underneath the tiller and out of the way. Also, the tiller will not be scratched.

On some high performance racing boats it could be an advantage to be able to vary the location of the attachment point on the tiller. If you mount the tiller fitting on a track that is mounted along the bottom of the tiller you can easily move the tiller

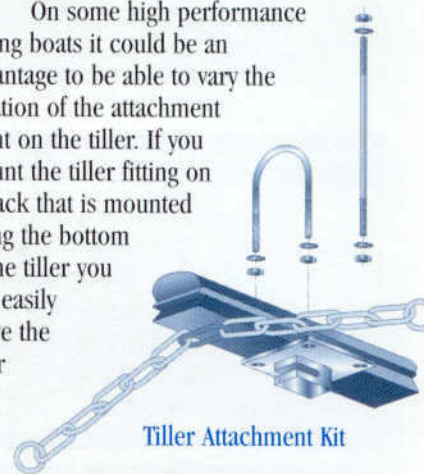

Tiller Attachment Kit

Installing the Pendulum Sheet Lines 3.5 (continued)

fitting in or out. With the plate mounted further forward on the tiller, the movement of the rudder will be less, since the swing of the pendulum is limited. Mounted further aft on the tiller, the rudder will move further, but it will take more power to move the tiller.

Moving the lines further forward along the tiller can sometimes give better downwind performance, preventing the vane gear from oversteering. Moving the lines aft, closer to the rudder shaft, will give you greater rudder movements and could be desirable when reaching. On most cruising boats this arrangement is absolutely not necessary. **In general, we prefer to mount the tiller plate at about 30" from the rudderpost** (rather than 20").

If the boat's rudder shaft fitting for the tiller is modified so the tiller can face forward or backwards, the backwards position could be used when the vane is engaged – the forward when hand steering. **The pendulum lines should NOT be crossed if the MONITOR is booked up to a tiller facing backwards.** This arrangement will give the boat more cockpit space. A shorter tiller can be used if a 2:1 purchase system is introduced but in general we prefer the standard 1:1 purchase.

Wheel installation 3.5.3

The wheel adapter drum is fastened with the clamps to the spokes of the wheel. It will fit wheels with 3,4,5,6 and 8 spokes. The MONITOR wheel adapter can be mounted either on the aft side or the forward side of the wheel, if there is enough room between the pedestal and the wheel. If this is not the case, or if the boat has or will have a pedestal mounted autopilot, the MONITOR wheel adapter has to be mounted on the outside, aft of the wheel.

If the adapter cannot be clamped onto the wheel, which can be the case on wooden wheels, it can always be bolted on by separating the fixed inner part from the moving drum. You then have to drill holes and through bolt the fixed part to the wheel. After this, the adapter is reassembled.

In general, the locking pin should be lined up with the rudder center mark on the boat's wheel as nearly as possible.

As with a tiller, it is possible to lead the pendulum lines BACKWARDS onto the wheel adapter. This makes the MONITOR inoperable.

With wheel steering, the lines SHOULD NOT be crossed. It is possible to lead both pendulum lines on either the starboard or port side, as well as leading the port line on the port side

and the starboard line on the starboard side. Normally, both lines would go to one side only and leave the other side open for passage. Access to space under the seats and other cockpit arrangements often determine the side. Lines from both sides could be preferred on boats with a cockpit traveler.

If both lines are led on the STARBOARD side of the boat, the STARBOARD SHEET SHOULD PASS OVER THE TOP of the wheel adapter drum and the PORT SHEET UNDER the drum.

If both lines are led on the PORT side of the boat, the PORT SHEET SHOULD PASS OVER THE TOP of the wheel adapter drum and THE STARBOARD SHEET UNDER the drum.

If the pendulum sheets are led from BOTH sides, BOTH SHEETS SHOULD PASS OVER THE TOP of the drum.

The brackets that hold the blocks where the pendulum lines leave the MONITOR frame are adjustable in the up and down direction. These brackets each have four holes for the two bolts holding each block. The holes allow change of the block position to port, starboard or straightforward direction.

In order to avoid overrides and jamming, sheets should not go more than

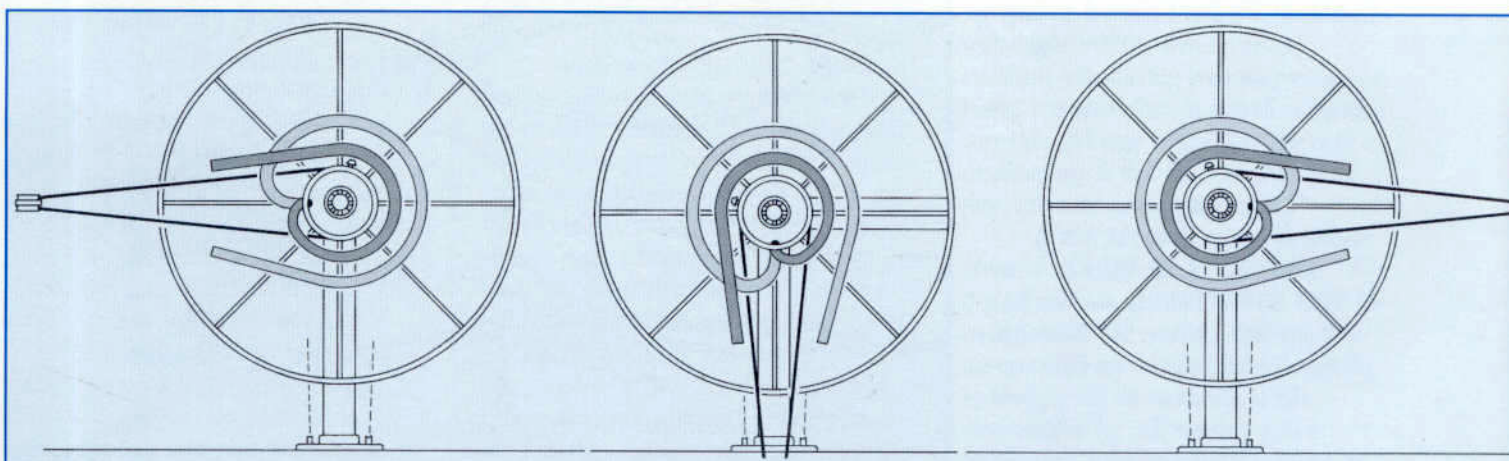

Both lines from port

Both lines from below

Both lines from starboard

Installing the Pendulum Sheet Lines 3.5 (continued)

three-quarters of the circumference of the drum (one full turn if the lines are led from both sides) before passing through the holes inside the drum. The wheel can now turn half a turn to port and a half turn to starboard. When the pendulum is straight down and centered between the frame legs, the two holes in the inside face of the drum should be midway between the pendulum lines.

If the holes are on the opposite side, away from the pendulum lines, the MONITOR will work somewhat but the wheel will only be able to turn a quarter turn each way.

The MONITOR Wheel Adapter is delivered with two 6' lengths of $\frac{3}{16}$ " Spectra line secured to the drum with stopper knots. These lines should be tied to with the Pendulum lines from the MONITOR using a detachable knot, which will allow you to tension the lines while the MONITOR is in use or untie them, when needed. (If you expect to be in an anchorage for a couple of weeks or longer you will also be able to untie them easily to free up the cockpit. You would add this to the routine, just like coiling your main and jib sheets.)

We recommend both lines be joined to the pendulum line with a "MONITOR Special" knot. (See the illustration.) Determine where the lines are to be joined. On most installations the lines will go between the Wheel Adapter to the coaming and then back to the vane. In such cases the lines are usually joined halfway between the wheel and coaming — usually where you have the longest run without blocks. You need a minimum of 12"–18" on either side of the "MONITOR Special" knot to allow for the back and forth movement of the lines as the servo-pendulum on the MONITOR moves from side to side.

It is easy to experiment with the tension even in high speed when there is a lot of pressure on the lines as the lines jams themselves slightly. However, ***make sure not to over tighten the lines.***

This is the most common mistake in the early days of MONITOR sailing.

The 3'–4' tail should be in the line coming from the MONITOR. The extra line will come in handy when you want to change chafe points on the pendulum line. (See paragraph 3.5.1.)

SUMMARY: There are many arrangements used to lead the lines to the wheel adapter. The principles outlined above should be adapted to whatever arrangement you use. We recommend that you, at least initially, use the MONITOR "Special" knot to join these lines. After using the MONITOR to the point you are completely satisfied with your arrangement, eye splices, snap shackles or other systems can be incorporated into your system.

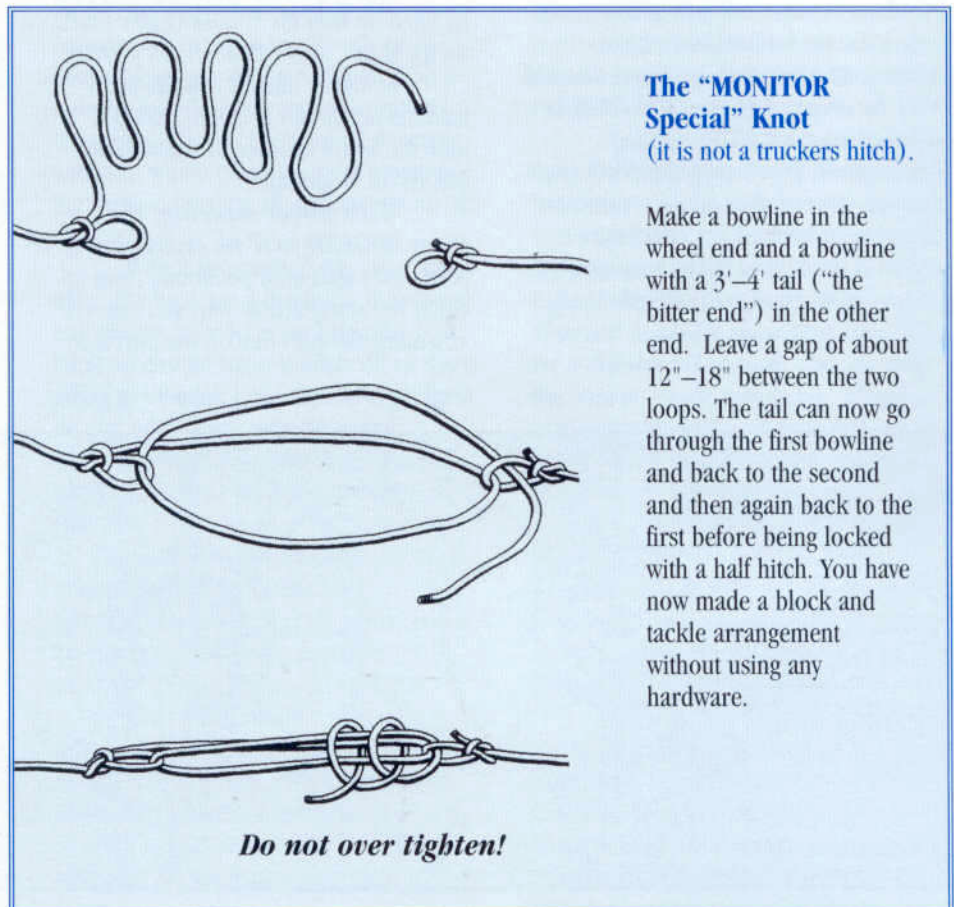

The "MONITOR Special" Knot
(it is not a truckers hitch).

Make a bowline in the wheel end and a bowline with a 3'–4' tail ("the bitter end") in the other end. Leave a gap of about 12"–18" between the two loops. The tail can now go through the first bowline and back to the second and then again back to the first before being locked with a half hitch. You have now made a block and tackle arrangement without using any hardware.

Do not over tighten!

Pendulum lines to blocks at the bottom of legs 3.5.4

For boats with open transom or with the cockpit floor more or less at the same level as the bottom of the MONITOR frame legs, a special custom arrangement might be preferred. The pendulum lines normally exit the MONITOR at the level of the upper tubes. If you bypass the blocks inside the frame you can instead install blocks at the bottom of the legs. The blocks that are normally mounted on the brackets outside the frame can be used, but the bushing has to be drilled out to make room for a 3/16" bolt. The bolts should also be longer (1 1/2") and the head should be drilled to permit a safety wire. The blocks are located between the legs and the end fittings of the lower tubes. These blocks with larger center holes and 1 1/2" long, 3/16" drilled bolts are available from the factory.

The pendulum lines will now go to the blocks at the bottom of the legs and then straight forward to two blocks at the bottom of the pedestal. Only four blocks are used. Friction is minimized and the lines are hardly visible, especially if they go under a teak crating.

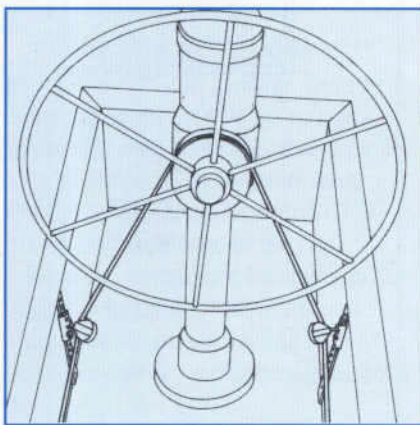

Tension adjustment can be arranged by mounting the blocks at the bottom of the pedestal on an adjustable track or similar.

For boats with a regular transom, not open, we suggest using glassed-in, large-diameter PVC tubing through the lazarette, between the cockpit and the hull. By using large diameter you

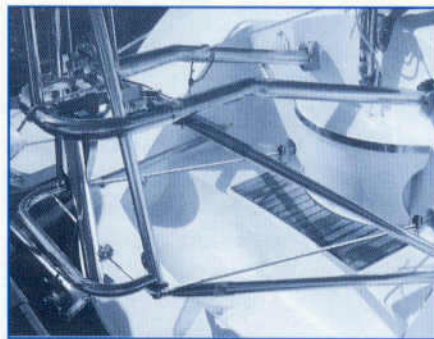

The pendulum lines go through existing cockpit drains on this boat



Blocks at the bottom of the legs

minimize the problem with chafe but more importantly, you add two large cockpit drains. You cannot have too many cockpit drains and they cannot be too large.

If there is not enough room for a "MONITOR Special" knot, tension can be arranged by mounting a block on a track.

Installing the Airvane Course Control Line 3.6

The airvane is remotely controlled by means of a thin (approximately 1/8") dacron line around the pulley mounted on the vane control shaft. An endless line with ONE FULL TURN around the pulley is preferred to prevent slippage.

This line MUST BE INSTALLED and kept UNDER TENSION when you are using the vane gear.

Otherwise, the airvane may gradually change its setting and take the boat off the desired course.

The pulley can be adjusted to the proper level on the vane control shaft by adjusting the screws (77). Make sure that the pulley is below the counterweight. The control line can be led practically anywhere on the boat to manipulate the airvane for a course adjustment.

In general, the line is led so that it can be easily worked from the helmsman's position or all the way to the companionway. The latter method makes it possible to control the MONITOR without going on deck which might come in handy on an ocean passage when you are down below and do not feel like putting your foul weather gear on to go on deck to make a minor course adjustment. Use fairleads instead of blocks since you want to have some friction in this line.

We recommend that the control line be either spliced or sewn together to form an endless loop. Before the splice is made, the line should go through a stainless steel ring attached to the boat with a piece of shock cord. By adjusting the shock cord you will adjust the tension of the control line. A stainless steel ring is cheaper and better than a block because here you want friction.

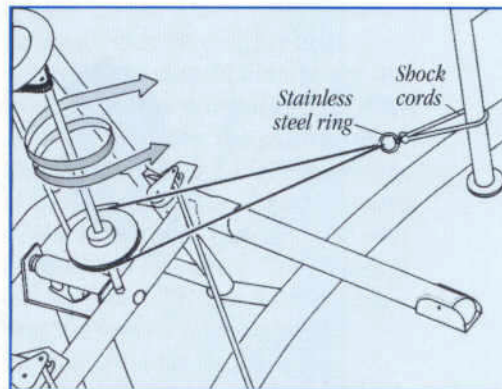

An endless line twice around the pulley, a stainless steel ring rather than a block and a shock cord for tension makes a basic arrangement for the course control line.

Becoming a Vane Sailor 4.1

As stated at the outset of the Manual, vane sailing is not a pushbutton phenomenon. During the years we have supplied windvane self-steering gears we have heard more than once from new vane owners who think that their gear does not work. After a few friendly hints, some experimenting and possibly consulting this Manual once again, the new vane sailor will admit that the vane gear does work on some points of sail, but not as well as expected. A few weeks later the same person shakes your hand with great enthusiasm. The vane gear is now fantastic, and he's given it an affectionate name in token of the closeness between himself and his most appreciated crewmember.

This part of the MONITOR Manual will make your own introduction a bit speedier. After giving a standard operating checklist and some hints for your first sail with the MONITOR, we discuss, in depth, the problem of balancing the boat for self-steering.

Std. Operating Procedure Checklist 4.2

Keeping the airvane mounted and the paddle lowered when the gear is not in use is generally not recommended as it results in increased wear and chance of damage. The MONITOR watervane should be kept in the "up" position for storage and latched into the "down" (engaged) position for use. ***Always try to avoid having the watervane drag horizontally behind the boat.***

Until you feel comfortable with the equipment, you may want to do the preparation work at your berth.

Ready the gear 4.2.1

Mount the airvane and lower the watervane paddle. When mounting the airvane at sea, make sure you are well supported and have a good grip on it. You should not attempt to lower the paddle and engage the latch when the boat is traveling too fast. Slow the yacht as much as necessary by rounding up and/or releasing sheets.

Assume the desired heading 4.2.2

Balance the boat for the desired point of sail 4.2.3

Balancing the boat for self-steering is crucial to performance and will now be treated at length. In essence, this involves choosing a sail combination and trimming the chosen sails to make the boat want to stay on the desired heading. If a wave or a gust takes the boat off course, the sails should work to bring the boat back by aiding the vane gear instead of fighting it.

Trim the airvane and engage the vane gear 4.2.4

With the boat sailing on course, use the remote airvane control to turn the vane's leading edge into the wind. The leading edge is the one NEAREST the lead counterweight. ***Insure the leading edge is pointing into the wind when the vane is upright.*** This neutral position indicates that the yacht is on course. (See also paragraph 2.2.)

When the airvane is set, engage the MONITOR by connecting the pendulum sheet lines to the tiller or engaging the wheel adapter. Before you engage the pendulum, make sure that it is in the center, or neutral, position. Especially with the wheel adapter, it is useful to mark the pendulum lines against a benchmark, which easily can be seen from your steering position. This mark will let you know when the pendulum is in the center, between the legs of the frame.

Fine tune for optimum course holding 4.2.5

After you have engaged the vane gear, you should remain at the steering station for a while to check the self-steering performance.

If the vane gear is constantly working to keep the boat from deviating to one side of the course, things will have to be improved. The same is true if the boat spends very little time on the desired heading and more time criss-crossing between generous margins on each side.

You should obviously strive and expect to have the boat stay close to the course line. Deviations should be small, on BOTH sides of the course line, and quickly corrected by the vane gear. This can usually be achieved by fine trimming, which involves readjusting the sails and traveler and compensating with the main rudder. With a tiller you would move the chain a link or two. With a wheel you would disengage the clutch pin and move one or two holes before engaging the pin again. Minor adjustments on the course setting mechanism might also be necessary.

Since fine-tuning is an important aspect of ultimate vane performance, it will also be treated in more depth in the following section. Here, we merely want to point out that if there is any remaining imbalance after the gear has been engaged, ***you should always try to work it out by trimming sail FIRST and by adjusting the connection the boat's rudder LAST.*** The objective of balancing should be to have as neutral a helm as possible. Basically try to steer the boat with sails alone. This ensures that the boat will remain balanced and steer itself over a wider range of conditions. Having the vane gear compensate for large imbalance limits its effectiveness.

Your First Sail with the MONITOR 4.3

If you have never sailed with a vane gear before, you should find the following hints especially helpful during your first trial.

Choose a day with decent breeze, if possible (10–15 knots or so). Trying out the vane gear with too much or too little wind will complicate your observation of what the vane is doing.

Do not over canvas. If your boat can be sailed well on a jib alone, you should **set a jib only** – at least for starters. Not dealing with sheets, potentially giboing booms, and a boat rushing onward with her lee rail under, will help you concentrate on the vane gear and how to make it work on all points of sail. Also, you will put off the problem of balancing the boat for self-steering until you are familiar with the working and operation of the MONITOR.

Start by sailing upwind without really pinching. Turn the leading edge of the airvane into the wind to bring the airvane upright and engage the pendulum lines on your tiller or wheel. The leading edge is the edge on the same side as the black counterweight. Make sure that the airvane is not mounted backwards. See 2.2.

Let the boat settle down with the self-steering controlling it. Even if the boat is not going exactly where you intend, give it a couple of minutes to assume a steady heading. **Go aft and observe the way the airvane moves** and how this movement sends the pendulum swinging and the boat's own rudder turning.

This 46' converted English Lifeboat with 3" planking and a barndoor rudder circumnavigated with a MONITOR. It can be considered a difficult boat, but the MONITOR had no problem.

Move the airvane setting slightly to form a **smaller angle** between the longitudinal direction of the boat and the leading edge of the windvane. Observe how the boat is taken closer to the wind. Once again, give the boat and the control system time to settle down. Retrim your sail sheet, if necessary.

Adjust the course again. When you are satisfied that the boat is sailing well on the new course for a while, change the airvane setting again by **opening the angle** to make the boat go further away from the wind. As the vane makes the boat bear off, retrim your jib sheet and let the boat settle down on the new course.

Go through all points of sail in a similar fashion.

Always allow the boat and the vane gear to settle down after you have made a change. The most common mistake is changing too many things too fast which prevents you from understanding what is happening and why. You will notice that the pendulum will only go two-thirds of the way towards the outside leg of the frame when the airvane is all the way down for maximum correction. Do not be alarmed. The gear set is designed to do this to avoid over steering. Full swing to the side will only be seen in strong wind conditions with higher speed.



Balancing for Self-steering 4.4

Problem boats and easy ones 4.4.1

Most boats have very little problem from the day the MONITOR is starting to take over the steering. However, we are sure that most skippers get more out of their MONITOR after a few weeks of using it. They have not only learned the operation of the MONITOR but they are probably more familiar with the boat after some time in the ocean. Obviously, not all boats are the same in terms of the ease with which they can be made to self-steer and the following is intended to be a shortcut to get the most out of your MONITOR.

The following factors make a boat easy for the vane gear to handle: moderate size, medium displacement, good course stability, moderate response to rudder, little or no helm on all points of sail, a steering system which turns easily and with little friction, a sail plan which allows many alternative sail combinations.

Problems are introduced by large size and displacement, very light displacement with accompanying fin keels and spade rudders, binding and friction in the steering system, or a rig or sail inventory which does not allow many options for sail combinations and trim.

This is not to say that such boats cannot be steered by the MONITOR. They do, however, require more insight and seamanship from the operator. This is the subject of the following discussion.

Balancing for Self-steering 4.4 (continued)

Light airs 4.4.2

"Does it work in light winds?"

This is a standard question asked of anyone involved with windvanes. Obviously, since the vane gear takes its signals from the wind and its power from the boat's movement through the water, the wind has to blow and the boat has to move for the vane gear to work.

How little it can blow and how slow the boat can travel with the gear still functioning depends to a great extent on the boat itself, on the skill of the operator, and on the point of sail in question.

If the boat is very large, it will generally take more force from the vane gear to operate its rudder. This is also true if there is much resistance to turning the boat's steering system. The vane gear has much less power in light airs, and the key to make it work is to reduce undue binding and friction. Light air performance can be vastly improved by balancing and fine-tuning. In general, the gear will do a better job in light airs on a small or moderate size boat and will remain functional down to about one knot of boat speed with the corresponding wind strength. However, a good sailor, balancing his boat properly, can make the vane gear steer even a very large yacht in surprisingly light conditions.

In these extremely low speeds, 1–2 knots of boat speed, the speed through the water might not be sufficient to move the servo-paddle to the side (which in turn moves the boat's main rudder). In such conditions the servo-paddle will act as an auxiliary rudder! Located far aft, the servo-paddle should be able to steer the boat in such low speeds unless the boat is very large. Of course, proper sail trim is essential.

Your new MONITOR is shipped with a high performance, light airvane which will enhance performance in apparent **wind speeds of 10 knots or less**. It is 60% larger than your standard airvane. See 4.5.1

The MONITOR will not work well in light air if the pendulum lines are too tight, since tight lines introduce too much friction in the blocks. With a tiller steered boat it is easy to adjust the tension by loosening the pendulum lines at the chain for the tiller fitting.

With a wheel installation it is difficult to adjust the tension while sailing unless there is a "break" in the line as previously explained. (See 3.5.3.—"MONITOR Special" knot.) In light air you will get better performance with looser lines that run easier through the blocks.

Running 4.4.3

"Does it work downwind?" This question is more common than the one about light winds. The problem with self-steering when sailing downwind is that you are moving in the same direction as the wind. Consequently, the wind velocity available to the airvane for correct signals is **decreased** by the speed of the boat.

While the servo-pendulum has ample power from the movement of the boat, the signals from the airvane become weaker, take longer to appear (and to return to neutral), and sometimes have difficulty overcoming frictional resistance in the boat's own steering system. If too much canvas is carried aft of the mast, the vane gear may not be able to steer the boat as well as expected and sail trim should be checked.

It follows that the faster a yacht can run before a given wind, the worse the problem becomes. The extreme case is that of a planing boat running in bursts at the same speed as the wind thus giving the airvane no wind from which to cue its signals. Such a boat is usually of very light displacement having a fin keel and spade rudder, which put higher demands on the MONITOR. However, we have many examples of successful downwind sailing even with planing ultra light boats, but these results have been achieved with experienced skippers.



Panache, a 40-foot ultra-light Bill Lee custom design with a fin keel and spade rudder. As a winner of the Single-handed Transpac with the MONITOR as the only steering aid (no autopilots), the skipper reported successful windvane steering in surfing speeds up to 18 knots. The MONITOR steered the boat for 6-and-a-half days under spinnaker.

The first and foremost remedy to downwind problems is to use the RIGHT SAILS and the right AMOUNT of sail.

Before the advent of mechanical vane gears, boats were sailed around the world self-steering downwind in the trades by use of twin headsails on poles. The trick to that is to sheet the twins a little bit looser than you would for maximum efficiency alone. If the boat wants to round up, the leeward sail starts spilling wind. The pressure from the windward sail gradually increases, acting like a giant finger gently nudging the boat back on course again until both sails are drawing equally.

If you are going to do a lot of downwind cruising, it might pay off to set the boat up for twin headsails. Combined with the MONITOR, this rig gives excellent self-steering even on problem boats. It is also efficient as well as being very safe and easy to manage. The only disadvantage is that the boat rolls more than when the main sail is used.

If the MAIN is carried, there should ALWAYS BE A FORESAIL poled out on the OPPOSITE SIDE to counteract the main. Although this set-up could not be used for self-steering by itself, it will be an excellent sail combination for self-steering with a MONITOR. If the boat has a tendency to round up you might be wise to take in a reef in the main.

Balancing for Self-steering 4.4 (continued)

If you have to drastically reduce sail in a squall, take the main sail down and leave the poled-out jib hoisted. This is contrary of what most sailors were taught. The boat does not have to be turned around to get the main sail but you have to help the main come down. With only a foresail the vane will handle the boat with relative ease.

Let us assume that only the main is carried. If the wind is fresh, steering will be like walking a tightrope. A very attentive helmsman may be able to keep the boat on course by instantly countering every move away from the course line. The choice of sail makes the boat increasingly unbalanced as it deviates from the desired heading. Once off course, the boat gets out of hand. Even full rudder will not keep the boat from rounding up or gibing once the process has begun. The pressure from the wind is concentrated behind the mast making the boat want to point into the wind as soon as it gets a little bit off its precarious equilibrium of sailing more or less dead downwind.

The situation can be likened to moving a cart by pushing it from behind with a stick (mainsail only) versus pulling it from ahead with a string (jib or twin jibs). It is practically impossible to keep the cart going where you want it to go with the stick, especially if any kind of speed is involved. A cart will follow nicely when we pull it from ahead.

A spinnaker should be used with caution with a mechanical vane gear. The spinnaker is set ahead of the mast and gives good balance as long as nothing goes wrong. The trouble is that a lot of things can go wrong. The tremendous power of the spinnaker makes the boat move faster downwind and consequently magnifies the problem of the weakness in the vane's signals. Since the sail is not hanked onto any controlling stay or track, it will continue to exert pressure long after a poled-out foresail would spill its wind. Because of the size of the sail, this pressure can be enormous and completely overpower the boat's rudder,

as anyone knows who has experienced his or her first spinnaker broach.

To sum up the discussion: Downwind, sails at the bow give the best balance and self-steering. If possible, they should be poled out on each side of the hull. When the main is used, a poled-out foresail on the opposite side should *always* counterbalance it. **Over canvassing should be avoided**, especially using a spinnaker in hard weather when it can easily lead to broaching.

Reaching 4.4.4

Seldom or never are we asked whether the MONITOR works well on a reach. In fact, reaching can be harder for the vane gear than other points of sail. If the velocity of the wind changes, the trim of the boat will probably change and the boat is no longer balanced. If this happens when you steer downwind the boat will just go slower or faster. With a one-masted rig there are fewer options for using sails well fore and aft to create pressure which make the boat return to the desired heading after it has swung off course.

With a two-masted rig, especially when the boat has a bowsprit, the mizzen and jib can be worked to bring the boat back on course when it bears off or starts going to weather. Even so, this is tricky to do and takes some experimenting.

Consequently, **the vane gear is MOST NEEDED when reaching**. However, faulty sail trim can over-power the gear, and it is, therefore, necessary to understand how to create the best possible balance. The greatest problem is keeping the yacht from rounding up when the wind increases in strength.

Only headsails or main and a poled-out jib can be carried to about 35–40 degrees away from straight downwind and will provide the best self-steering as long as they can be kept up. After that the windward pole must come down.

Again, using the main alone is not

the way to go. You can try to compensate for the greater weather helm with the rudder before you engage the vane gear, but any increase or decrease in wind strength is likely to change the balance. Once more, **you must strive to BALANCE THE BOAT WITH THE SAILS first and not use the rudder to compensate for a significant lack of balance**. The rudder should be used for fine tuning after the boat has been set up to sail on course as much as possible by itself.

If only one sail is used, a headsail should be the choice. However, the effect of a headsail on a reach is not necessarily to push the bow downwind unless it is hoisted very far out on a long bowsprit.

When the wind increases, many boats will experience increased weather helm even with only the headsail set. However, this weather helm is very mild compared to what the mainsail would induce under similar circumstances, and the vane gear can easily hold the boat on course.

When the main and headsail are used, both sails may work to bring the bow to weather. To limit weather helm, as well as great increases in weather helm during a gust, **each sail, but especially the main, should be sheeted LOOSER than you would do in a racing situation**. This will slow the boat an imperceptible bit. The effect is to make the sails spill their wind at a much earlier point when the boat wants to round up. The weather helm decreases, and the vane gear is capable of pulling the yacht back on course.

If you continue to have problems, reduce sail area, especially the main, and continue to release more sheets even though the leeches may flutter a bit.

When the wind drops significantly, the boat might want to bear off downwind, especially if the main rudder has been used to compensate for a lot of weather helm. This is one of the chief reasons why the rudder should not be a primary factor in balancing the boat. In this case, carrying the main is actually

Useful Hints to Get the Most Out of Your Vane 4.5

helpful. If the boat veers off, the main will cover the headsail(s) and catch all the wind moving the pressure behind the mast and making the boat want to round up again.

For successful self-steering on a reach: avoid EXCESSIVE canvas; rely primarily on the HEADSAILS FOR POWER; sheet the sails loosely; and use SAIL TRIM rather than the main rudder for balancing the yacht.

Hard to weather 4.4.5

Most yachts can be made to self-steer when hard on the wind without using the vane gear. Consequently, the vane will have little problem keeping the yacht on course. Because the movement is towards the wind, the velocity of the wind working the airvane sensor increases by the speed of the boat. The vane's signals will be true and strong.

To guarantee the best performance, DON'T KEEP UP TOO MUCH SAIL area and DON'T SHEET IN the sails too hard. Over canvassing and over sheeting will only heel the boat unnecessarily inducing weather helm which may become difficult for the vane to control in a gust.

Give it a chance 4.4.6

Armed with these hints on balancing the boat on different points of sail, you should have no difficulty making the vane gear steer your boat. After you have used the MONITOR awhile, it will steer even better. You probably will have learned a thing or two about sailing and balancing your boat. Give everything a chance to work and remember that some learning is necessary to get the most from your vane. The gain will certainly be greater than the pain. *You should expect your MONITOR to steer BETTER than an average helmsman.*

After you have set up the vane gear to steer your boat, you should remain in the cockpit for a couple of minutes observing the compass and the behavior of the yacht.

The boat should remain on the desired heading, *deviations should be small* and quickly corrected, and the vane gear should not be fighting to keep the boat from wandering off on one side of the course line.

If the boat has a persistent tendency to luff or bear off, it is *not properly balanced*. Sails have to be either sheeted in or out, reduced, or changed completely. A small adjustment of the boat's rudder may help, but the rudder should not compensate for large imbalances.

Usually, *releasing the main sheet* a bit works wonders in taming tendencies to round up.

The light air/high performance airvane 4.5.1

In addition to the standard airvane this new light airvane has been included with new MONITORS since summer 1997. It is about 8" taller than the standard airvane. It is also wider and has about 60% more area. Most of the area is at the top where it counts and it gives a much better signal in light air. It has been tested in 40 mph with no problems and we would not be surprised if you use it always except for the worst of weather. We suggest that you experiment and find out for yourself in what conditions each vane should be used.

The downwind problem 4.5.2

Sailing downwind under windvane is often considered very difficult.

In light air the windvane will have the same problem as a human helmsman in determining the direction of the wind. *Use the light airvane in WINDS UNDER 10-15 KNOTS apparent.* The MONITOR has to know the wind direction in order to steer the proper course. If there is enough apparent wind for the

airvane to register the wind direction, the airvane should be able to turn the servo-paddle. It is of course very important that the pendulum lines are not too tight. Once the servo-paddle changes the angle, the water will push the pendulum to the side and steer the boat. Because of the weak signals from light air, it is crucial that the installation and the operation of the MONITOR are done properly.

Sailing downwind in strong winds, the input from the wind is more than sufficient. The servo-paddle also has lots of power because of the higher boat speed. You should expect the MONITOR to steer better than a very good helmsman. If you experience breaking waves a rested helmsman might do better because the MONITOR has no eyes. Such conditions are very unlikely, even if you circumnavigate.

The MONITOR works in these extreme conditions but understanding your MONITOR becomes more important.

Friction & binding in the MONITOR 4.5.3

Friction and binding that interfere with the airvane's ability to rotate the servo-paddle are deadly enemies of light air performance. Friction and binding may result from salt build-up in the vane's bearings. This problem disappears after fresh water is flushed through the gear. Rain will normally take care of this. If a hose with fresh water is available, we recommend that you hose the MONITOR off periodically. *Do not use oil or use a spray lubricant* in the ball or roller bearings of the MONITOR. Oil will gum up the gear.

Friction in the yacht's steering system 4.5.4

In some boats the yacht's own steering is the culprit. The vane gear is very powerful in a hard blow when the boat is moving fast, but in light airs performance drops dramatically if the boat's own steering has a lot of friction.

Useful Hints to Get the Most Out of Your Vane 4.5 (continued)

Everything possible should be done to free the movement of the boat's own rudder.

On a wheel steered boat, you should easily be able to spin the wheel from left to right using only two fingers approximately a foot out from the hub of the wheel. This check should be done when the boat is at the dock.

If the boat is balanced and the vane gear still has problems controlling the course, **friction** and **binding** are the first suspects. All moving parts should be checked from the airvane through the connecting rod, gearset and pendulum to the boat's own rudder and steering mechanism.

Friction in the pendulum lines 4.5.5

If there is no friction in the MONITOR itself and the main rudder seems to be easy to move, there could be friction in the pendulum lines that connect the two.

Use only good quality bearing blocks. Use the **minimum** number of blocks. The straightest line with the minimum number of blocks will give the least friction. Use 1/4" Spectra or a line with minimum stretch. Thicker lines will not run freely.

The tension of the lines could also be a problem. If the lines are too tight, you introduce a lot of friction, which can be overcome in strong winds but not in light air. **A very common mistake is to OVER TIGHTEN the lines.** However, if the pendulum lines are too loose, you will waste the correction from the MONITOR. The MONITOR will do the job but because of too much slack in the lines, nothing – or too little – will happen with the main rudder. A good installation always has an easy way to experiment with the line tension under sail. (See end of paragraph 3.5.3.)

The autopilot friction 4.5.6

Many boats have autopilots to complement their windvane. It is very important that the autopilot not cause any drag on the boat's steering system.

The small, inexpensive, cockpit mounted pilots are great for windless days and friction from these autopilots does not seem to be a problem.

Some of the larger, heavy duty under deck pilots have been known to add friction to the boat's main steering system even when the autopilot's clutch is disengaged. If this seems to be the case, you should mechanically disengage the autopilot at the linkage. The steering wheel should be as easy as possible to turn whether you are steering the boat yourself or the MONITOR is doing the job.

Autopilot Hook Up to the MONITOR 4.6

If you are making a landfall on a small, low atoll, you might have reason to sail on a magnetic course rather than in the relation to the wind.

You might then prefer to use a small cockpit mounted tiller pilot hooked up the MONITOR. You would use the MONITOR's powerful servo-paddle to move the boat's rudder, but the signal would not come from the wind.

If you attach the tiller fitting for the autopilot to the counterweight of the MONITOR, the tiller pilot will manipulate the counterweight and provide input to the servomechanism.

You could also fabricate a small short airvane and put the autopilot tiller fitting on top. The height of the MONITOR mounting and the design of the stern pulpit will determine the most practical way of hooking up the autopilot to the MONITOR.

You should be aware that the small cockpit mounted autopilots push 80–100 lbs. If you design a hook-up of your autopilot to the MONITOR, the system should have a safety release that makes the autopilot jump off the fitting it pushes against. If there is no safety

system you could damage the autopilot, the MONITOR or both. This could happen if the skipper takes over the steering but forgets to disengage the autopilot.

We **do not recommend** this type of arrangement be used for extensive powering because the servo-paddle will be positioned in very turbulent water from the propeller wash. This will most certainly cause a lot more wear on the MONITOR than sailing with the MONITOR in the roughest possible conditions. You can compare it to a filled sail and a sail fluttering violently in the wind.

Under power the engine is charging the batteries, and, in those conditions, we believe it is better to hook up the autopilot directly to the boat's steering rather than putting unnecessary miles on the MONITOR.

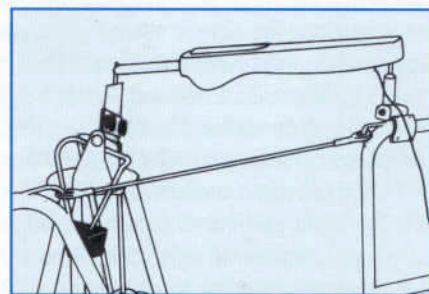

Autopilot controls small custom "airvane"

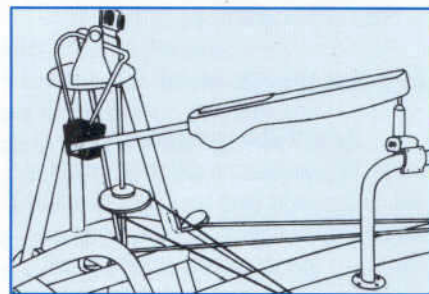

Autopilot controls MONITOR counter weight

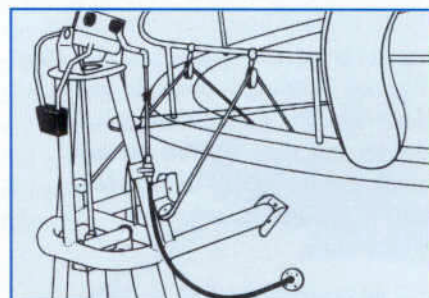

Autopilot in lazarette is connected to MONITOR airvane assembly with Morse cable

Appearance 5.1

The MONITOR has been made of type 316L stainless steel since 1997. After fabrication, the individual stainless parts are Electropolished in a chemical bath to remove impurities from the surface and cover metal welds. The last step is the assembly of the individual parts to make a finished vane gear.

Regular Maintenance 5.2

The pendulum sheet lines are the hardest working part of the MONITOR vane gear. Inspect your lines frequently and re-adjust leads for minimum wear if there is a problem. You can keep a set of pendulum lines much longer by changing the chafe points frequently rather than waiting until the lines are nearly gone.

In order to avoid changing lines at sea, always inspect the lines before a long passage – just as you would your rigging and halyards. If you are forced to change lines at sea we recommend that you sew a new line to the old line before it breaks. Then you can simply pull the new line through the frame. If this cannot be done because the pendulum line already has broken we strongly recommend that a separate line be used to prevent the pendulum from swinging and hurting the person doing the work.

If you change lines we recommend our custom 1/4" Spectra, which is a very strong but thin line that should run smoother through the blocks and minimize friction.

The stainless construction and the materials of bearings and bushings make the MONITOR more or less maintenance free. **DO NOT put grease into the bearings**, as most grease will emulsify or form a hard paste after working together with salt water. Friction in the MONITOR will be the result.

The MONITOR bearings and bushings are made from materials that work better with water on them. Maintenance consists of hosing the gear

with fresh water when you have the opportunity. Take care to flush all places that have bearings to clean out salt deposits. Regular rain often takes care of this.

Vibration from the engine might cause bolts and other fastenings to loosen and you should check for this problem periodically. Use Loctite if this is a problem. The bolts at the bottom of the legs in the main frame hold the lower tubes and should be safety wired for ultimate loss prevention.

Preventing Problems & Damage 5.3

Collision avoidance – removing the servo-paddle 5.3.1

As the vane gear is mounted outboard of the hull, it is vulnerable to collision. Unfortunately, being run into by other less than expert skippers sometimes damages vanes. This can happen in a marina as well as in an anchorage. Even a bump may do a lot of damage when a vessel weighing many tons executes it.

Be aware of the danger to your vane gear from collision. If possible, berth your boat with the stern in. Be ready to fend off in crowded situations. The MONITOR strut guard, which connects the two legs make the MONITOR main frame very strong and it also protects the pendulum.

If you will not be using the vane gear for a period of time, or if there is a serious possibility that the pendulum may be damaged, you should take the paddle off the gear. This is very easily done by taking out the latch hinge pin (76) and removing the entire hinge/water vane assembly.

Remove the airvane 5.3.2

Certain small measures will greatly help in keeping your vane gear in good working order.

When you have finished sailing with the MONITOR, remove the airvane

from the vane gear. Leaving it on is probably not going to hurt either the airvane or the bearings and fittings that hold it as these parts are as strong as the rest of the gear. However, it will not do any good to have the airvane banging from end stop to end stop for days and weeks. Eventually, if it is not dismantled, there will be some wear as well as aging of the airvane from exposure. **It is a much better idea to store the airvane inside the boat whenever it is not being used.** Store it in a flat and dry location.

It is a good idea to secure the airvane with a lanyard to prevent a loss should it work itself loose. As has been already pointed out that there is a small hole in the front lower end of the airvane for this purpose.

Safety line/pull-up line on the water paddle 5.3.3

The MONITOR water paddle is normally positioned safely behind the hull, protected by the boat's own keel and rudder from forward impact. It is also protected by its own ability to swing sideways and chances are very small that the pendulum will get damaged.

However, if the pendulum sustains a very hard blow, it has a safety tube in its middle. This tube is weaker than the rest of the pendulum and should buckle before more serious damage is caused by impact. This could also happen if a log or a crab pot got stuck between the boat's rudder and the MONITOR.

Your gear is delivered with a line attached to the shaft of the water paddle, below the safety tube. This line has a dual purpose. It is a safety line but it is also used to pull the water paddle out of the water to store it in the unlatched, "up" position. **The securing line is best tied on just UNDER the lower bolt** for the safety tube connection. It should be led outside the strut guard, through the frame on the starboard side of the pinion gear and then secured to the stern

Preventing Problems & Damage 5.3 (continued)



pulpit. To make the water paddle rest close to the frame, we recommend a shock cord from the aft main frame support tube to the hole in the paddle.

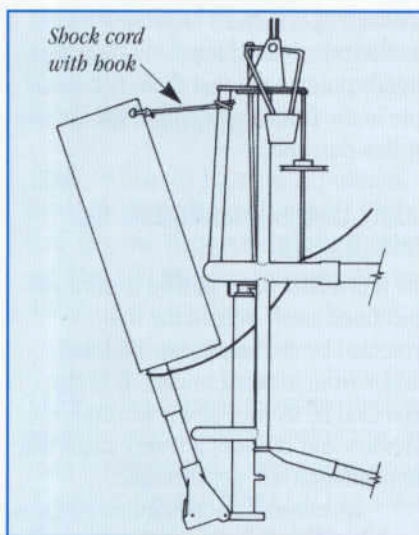

Hard weather 5.3.4

Hard winds and fast speeds make the MONITOR very powerful. People have reported using the gear in extreme storm conditions, and we have many examples of the MONITOR steering under bare poles for days in a gale. Do not be afraid of leaving the steering to the MONITOR in storm conditions. It should steer a lot better than a tired helmsman. **The upper limit for a MONITOR – the situation when you would have to take over – is when the boat is threatened by breaking waves.** The MONITOR cannot see a freak wave and you might be better off steering the boat yourself. In very big seas, there can actually be a lack of wind in the trough

between two waves. This lack of wind would interfere with the steering ability of the vane gear and you might be better off by adding to the sail area to keep the boat moving and retain steering control.

In really bad weather, the vane gear itself is actually better protected left engaged. The pendulum lines take the strain of big waves hitting the pendulum, and the resistance from the boat's own rudder will act as a shock absorber through these lines.

Under extreme storm conditions, trying to heave-to or running before the wind, it is questionable whether or not you should unlatch the pendulum and store it in the "up" position. The latch part of the gear is definitely weaker when up. **NEVER let the paddle stay in the floating, horizontal position.** This position will put a concentrated load on the "ears" of the hinge and is not recommended.

Heaving-to, you are probably protecting the pendulum better by leaving it down, as long as you CLEAT THE PENDULUM LINES OFF in order to CENTER the pendulum and prevent it from forcefully banging into the frame legs. If you choose to get the paddle out of the water, you should definitely secure it in the center by cleating the pendulum lines.

Trouble-shooting Guide 5.4

The MONITOR has proven itself for many years and on thousands of installations. You should expect it to steer better than a good helmsman but from time to time we have boats when this is not the case. Unlike an autopilot, which has a black box that only the manufacturer or a shore based service facility can understand, the MONITOR is logical and mechanical and can be fixed at sea.

This trouble-shooting guide shows some of the common problems – you might think these are a few ridiculous

reasons for inferior MONITOR performance, but they are actual cases. We are repeating a few instructions mentioned earlier in this manual. On a normal boat with a decent skipper, there is no reason to accept poor MONITOR performance. We hope that this list will give you guidance and make sure that you get the most out of your MONITOR.

Faulty installation of the MONITOR

5.4.1

Some problems stem from errors in installing and rigging the gear:

- **MOUNTING.** *The gear is mounted too low.* The mounting of the gear should obviously be in accordance with the installation drawing and the instructions of this Manual, but we have seen many gears that are mounted too low (NEVER too high). This does not seem to be a real problem, but you will get more drag and higher loads on the gear. **You should be aware that cutting the safety tube to get the water paddle up higher might not be a good idea to correct this. A shorter pendulum will have less power because of the decreased leverage.** A 50-footer might very well need a +6" safety tube because of the increased power that the longer tube generates. (See paragraphs 3.2.3 and 3.2.4, or consult the factory for guidance.)
- **WHEEL.** *Lines on the wheel adapter are incorrectly led.* If they enter the adapter on top instead of at the bottom of the adapter, the MONITOR will steer the wrong way. This is a very obvious mistake. Another common mistake is that the *lines do not have the correct wrap around.* The knots on the wheel adaptor have to be in the direction where the lines came from on a starboard or port installation. This gives the lines a three-quarter wrap-around, which will give the maximum half a turn to the right and half a turn on to the left. *If the knots are meeting*

opposite to where they came from, the wheel will only turn a quarter of a turn in each direction. This mistake might be more difficult to detect since it will turn the wheel correctly but not far enough. See paragraph 3.5.3.

- **TILLER** *Lines to the tiller are incorrect. The pendulum lines have to CROSS, and the tiller attachment should be 20"–30" from the aft end of the tiller.*

If the tiller attachment is too far forward, you will get lots of power but not enough movement on the tiller. If the tiller attachment is too far towards the rudder, you will get lots of pendulum movement but less power. Placement at 30" is correct for most boats. See 3.5.2

- **BLOCKS** *Friction in the blocks.* Make sure that GOOD blocks are being used from the MONITOR to the wheel or tiller. They should preferably be good quality roller or ball bearing blocks with 2" diameter or more. **NEVER use fairleads for the pendulum lines.** The friction will kill the performance if you use too many blocks to go around obstructions. This will mean more friction. **Use as few blocks as possible.** Your priority should be performance.

Blocks incorrectly attached. NEVER attach the pendulum blocks to a shock cord or a lifeline. The corrections

from the pendulum will not move the rudder, only the shock cord or the lifeline. Rigid blocks are better than swinging blocks – also quieter.

Improper alignment of blocks.

Make sure that all the blocks are properly aligned. If not, you will have friction in the system and chafe will damage the pendulum lines. If the lines go through the hull or a coaming, make sure that the hole is large enough and the lead is clear.

- **IMPROPER CLEARANCE.** *Airvane and counterweight DO NOT swing all the way.* Make sure that you have full

clearance for both airvane and counterweight. Nothing should touch stern pulpit, radar mast, antennas, BBQs, or outboards, etc.

- **LINES.** *Pendulum lines have too large a diameter.* Use 1/4" Spectra or minimum-stretch pendulum line. Thicker lines will not run freely through the blocks and friction will be the result.

Faulty operation of the MONITOR 5.4.2

Other problems stem from operating the gear incorrectly:

- **LINES.** *The pendulum lines are too tight or too loose.* Too tight is a very common problem. It's a little bit like sheeting the sails too hard. Try looser lines, but not too loose! You have to experiment and this is easy to do if you use the recommended "MONITOR Special" knot. (See end of paragraph 3.5.3.) Tighter lines are generally used in strong winds when you do not want to waste any corrections and you have plenty of power. In light wind, you **have to** loosen the lines to minimize the friction in the entire system. Once again, experiment and learn how to get the most out of your MONITOR.
- **OFF CENTER.** *The clutch pin on the wheel adaptor is engaged when the pendulum is off center.* In order to avoid guesswork we suggest that you mark the pendulum lines with a marking pen when the water paddle is between the two legs of the frame. Mark them close to the last blocks to the adaptor so it is easy to see when you are at the wheel. If the boat has weather helm you correct this the way you are normally steering. The steering wheel will not be centered when the adaptor pin is engaged but the pendulum should be centered.
- **AIRVANE.** *The lead weight is pointing away from the wind.* It has to point into the wind. Follow the label on the airvane. *The airvane is mounted backwards.* You could get away with

this in strong winds but in light winds it would be like having two reefs in the main when it is not windy. Again, follow the label on the airvane. Also see 2.2.

The boat's steering system has excessive friction. 5.4.3

This problem is mostly associated with wheel steered boats. If you have a stiff wheel steering system you will have poor windvane performance, autopilots will suffer mid ocean meltdown and you will have a tough time steering the boat yourself in rough conditions. We have devised a very unscientific method of determining when stiff is stiff. Do the "two finger test." When the boat is at the dock, you should try to put two fingers on one of the spokes of the wheel about one foot from the hub. Now, turn the wheel all the way to port and all the way to starboard. You should be able to do this without difficulty. If it is hard to turn the wheel, your steering system is too stiff. Steering system problems that we have encountered are listed below:

- *The autopilot creates drag.* Under-deck autopilots normally have a clutch and, in theory, there should be no drag when the clutch is engaged. We have found that some autopilots drag and some don't. If you physically disengage your autopilot connection at the rudder you should be able to feel if the autopilot drags when you turn the wheel. If this is on a long passage, we suggest that you try this test, and, if necessary, disengage the autopilot if you want the windvane to work properly.
- *Wire blocks are poorly aligned or blocks have not been lubricated, making steering stiff.* We suggest that you inspect and service the steering system on a regular basis and treat it with the same interest as your rigging. Failure of either one is pretty disastrous at sea and it is surprising to hear how many sailors have NEVER inspected their steering system.

Trouble-shooting Guide 5.4 (continued)

(continued)

- Tight rudder bearings sometimes cause a stiff steering system. This problem is often found on amateur built boats. Allowance has to be made for the swelling of the synthetic bushing when the boat is in the water. The problem is not common on older boats that have been worn in by years of use. Builders of production boats are normally familiar with the swelling problem and have allowed for it.
- Play in the rudder system will make the steering less precise. When the MONITOR is making a correction nothing happens with the boat's rudder. Try to get rid of the play.

The MONITOR is damaged and needs repair or adjustment 5.4.4

It is very unlikely that a new MONITOR will have a problem. The sea very seldom causes problems. A collision with a dock or another boat can do it, and sometimes the skipper is not aware of it because he wasn't on the boat when it happened. A quick inspection – BEFORE you leave the dock – can determine that the MONITOR is in working condition.

- Check that the airvane can move easily from left to right. There should be no friction.
- Loosen the pendulum lines and make sure that the pendulum can swing easily between the legs. The holes on the line attachment on the pendulum should line up with the blocks at the bottom of the legs. If the holes are forward of the blocks, it indicates that the pendulum has been pushed forward – as the boat was backed into a dock or was hit from behind by another boat.

- Check that all the blocks are moving freely.
- Check that the watervane is straight fore and aft when the airvane is straight up. The actuator shaft (57) can be adjusted by twisting either clockwise or counterclockwise, which will make the shaft longer or shorter. ***If the length of the actuator shaft is not correctly adjusted the MONITOR will not work. This adjustment is extremely important!*** Also see paragraph 6.3.1.

Boat is sailed incorrectly 5.4.5

If a boat has too much or too little sail area, or is improperly trimmed, it will be difficult for a person to steer the boat. You can expect an autopilot or a MONITOR to have the same problem. Check out the following, and make the necessary adjustments.

Do you have:

- too much sail area?
- too little sail area?
- the sails not trimmed correctly?
- the wrong choice of sail combination?



Swing the pendulum between the legs of the MONITOR to check the alignment.

MONITOR as Emergency Rudder – MRUD 5.5

The MONITOR is designed to steer using the boat's own rudder but, in an emergency, the MONITOR can probably also be used as an emergency rudder.

If this is necessary, the pendulum lines have to be DISCONNECTED from the tiller or wheel. The pendulum should then be positioned as vertically as possible. If the boat is on a starboard tack, it is probably best to move the pendulum as far as possible towards the port leg of the frame. The pendulum lines should be cleated on a stationary part of the boat, and it might be a good idea to install additional lines between the legs and the pendulum.

With the MONITOR paddle in a stationary position, you can now operate the counterweight by hand or by a line. The MONITOR water paddle is now working as a small rudder. Great attention has to be taken to balance the boat since the rudder is very small.

This system will work on smaller boats (under 30') and should help you get back to port. It is not perfect, but it is a lot better than trying to steer with a spinnaker pole. We have several examples of successful use of the MONITOR as an emergency rudder.

The MRUD – MONITOR Emergency Rudder Conversion Kit is available as an option and is designed to provide emergency steering for boats up to 50 feet. The MRUD can be installed at sea, and all the parts are contained in a bright orange bag that also can be used as a safety flag. (See paragraph 7.)



Repair Overview 6.1

The sea punishes everything on a boat. The windvane self-steering gear is possibly the hardest working piece of equipment on a cruising sailboat. Unfortunately, it cannot be engineered with mammoth dimensions, as this would interfere with its ability to steer in anything but a hurricane.

A MONITOR that is returning from a circumnavigation will normally have worn plastic bearings and bushings. The result is a MONITOR that is pretty sloppy with quite a bit of play in the connections. The gear needs service and the worn plastic parts should be replaced in order to make the gear nice and firm.

We recommend maintenance after approximately 15,000 Miles or 5 years of use the MONITOR. You should then consider replacing all plastic bushings and bearings, which are available as a kit (part #810). The standard spare parts kit, which most customers purchase when they buy their MONITOR, also contains these parts. The old worn parts still work and we suggest that you save them for an emergency.

We have many examples of MONITOR gears that have circumnavigated without any maintenance or repairs! The stainless construction of the MONITOR combines great strength with the necessary lightness to make the gear efficient in all conditions. If damaged, stainless steel can be easily welded and worked. Regular hand tools are most often all that is needed to make repairs, and the corrosion resistant materials always make it possible to take the MONITOR apart and reassemble it, even after long use.

Hopefully, you will never have to make major repairs to your MONITOR, but, if you do, the instructions in this section will enable you to handle even more complex repairs and replacements.

If possible, you should perform more involved surgery on the gear with the vane dismantled from the hull. It is

easy to lose bearings and other parts in the water if you are not used to taking the vane gear apart.

The quickest way to unbolt the MONITOR is to unscrew the four bolts (86) that hold the upper and lower tubes to the hull brackets (83). If you take the upper tubes out of the frame (58), you should be aware that there are compression sleeves (85) around the bolts inside each mounting tube. When you pull the bolt, the sleeve is loose and may fall in the water unless you used a sealant to hold it in place when you installed the vane. Always keep a rope on the gear when you are mounting or dismantling it from the hull.

Repairing the Airvane Pivoting Assembly 6.2

Disassembling the airvane control assembly 6.2.1

To repair the airvane pivoting assembly you should take the disc base (11) off the gear. First take off the pilot shaft (20). Unbolt the pilot shaft plate (16) that holds the upper end of the shaft. Keep downward pressure on the shaft. It is very easy to lose the spring (25) and washer (17) at the bottom of the shaft if the shaft accidentally gets out of the nylon bushing (15) in the frame. The chain (18) cannot fall off since it is captive around the actuator shaft (57).

Disconnecting the actuator shaft 6.2.2

After you have removed the pilot shaft (20), you have to disassemble the actuator shaft (57). Do this by loosening the locknut (56) and rotating the shaft until the threaded clevis (80) is unscrewed from the shaft. Note: there is a threaded nut welded to the top of the clevis. **Be sure if you are loosening this mechanism that you are turning the actual locknut and not**

the welded portion. While unscrewing the clevis, hold onto the chain (18) so that you don't lose it.

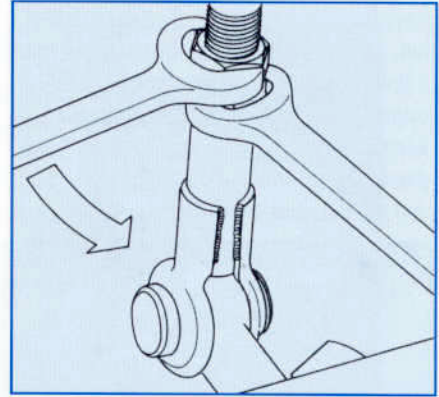

Hold lower nut—turn upper nut

When the pilot shaft and actuator shaft have been disconnected, you can remove the screws (59 & 60) that hold the airvane base disc (11), allowing you to remove the disc together with the airvane pivoting assembly.

Correct spacing of the airvane yoke 6.2.3

To reassemble the airvane pivoting assembly if it has been damaged, you may have to begin by adjusting the spacing of the yoke (8). Tighten or loosen the nut on the shaft (6) for the airvane. It is important that you do not tighten the rotating airvane weldment tube (5) between the ends of the yoke to the point that the bearings (2, 3 & 4) are pinched. **The minimum inside distance between the ends of the yoke should be about 6 1/4".** At the factory the shaft nut is tightened to the bottom of the thread. If larger space of the yoke is necessary, stainless steel washers are used to adjust the distance. If the airvane weldment tube (5) is too loose in the yoke, the Delrin balls (3) may escape from the bearings.

Repairing the Airvane Pivoting Assembly 6.2 (continued)

Realigning the airvane yoke 6.2.4

In case of collision damage you might have to realign the yoke (8). Use the 1/2" stainless airvane shaft (6) and pass it through one end of the yoke and see if it lines up with the hole in the other end. If not, use the shaft to bend the yoke end until it lines up. Then, pass the shaft through the opposite end and repeat the procedure. Keep adjusting the yoke ends until the shaft passes freely through both holes in the yoke and the yoke has a 6 1/4" gap.

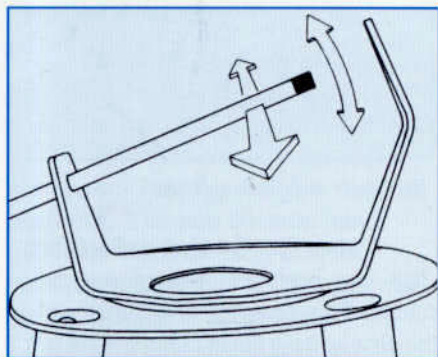

Use the shaft (6) to make sure that the holes in the yoke are aligned.

Installing bearing cups 6.2.5

If you have lost the bearing races (4) from the tube in the airvane weldment (5) and need to replace them, be aware that the bearing races should fit tightly in the ends of the tube. If the tube is too large, bang it lightly with a hammer to upset its shape somewhat so that the bearing cups will need to be forced in place and will be held tightly.

Assembling the airvane bearings 6.2.6

To fit the 18 Delrin balls (3) at each end of the airvane weldment tube (5), you need to use a paste to hold them in place. **Do not use GREASE of any kind.** The paste should be water-soluble, such as hand-cleaning cream, shaving cream or whatever else is handy and will keep the balls in place. After you have loaded one end, complete the bearing by putting the bearing cone (2) over the balls. Keep your finger on the cone (2) and turn the tube over so that it rests on

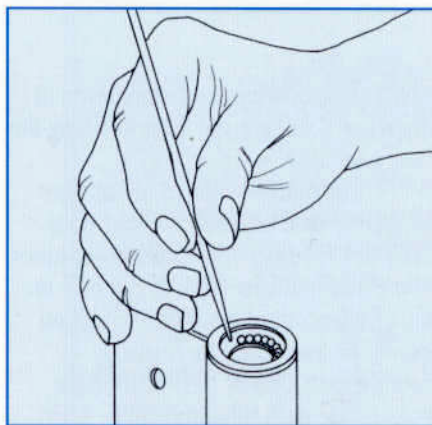

Never use grease to hold ball bearings

the cone, keeping the balls in place. Repeat the procedure for the other end of the tube, and when the second cone is in place, put the tube and bearings into the yoke. Keep constant pressure on the cones so that the bearings do not split open. Pass the shaft (6) through the yoke and the bearings and tighten the nut on the shaft. Check that everything moves freely and without binding.

We like to point out that the MONITOR purposely uses bearings without cages. There is no doubt that caged bearings are installed easier, but, as you know from cleaning your winches repeatedly, the reason for the cleaning is that dirt and salt will accumulate between the bearings and the cage making periodic cleaning necessary. With the MONITOR system, it will take longer to mount the bearings but dirt and salt will not get stuck. The bearings become maintenance free with the help of an occasional rain water shower.

Remounting the airvane base and airvane pilot shaft 6.2.7

The easiest way to remount the airvane pivoting assembly is to mount it on the base disc (11) with the disc in a vise. You can then put the entire assembly back on the frame and fasten it with the three screws (59 and 60). Put the chain around the actuator shaft (57) and screw the threaded actuator shaft clevis (80) into the end by rotating the shaft.

Slip the chain onto the teeth of the large airvane control sprocket (40). Hold the spring (25) and washer (17) onto the bottom end of the pilot shaft (20) and insert the end into the nylon bushing (15) in the frame. Keep downward pressure on the shaft and move it to the side so that the chain can be slipped onto the small sprocket welded at the upper end of the pilot shaft. Install the washer (17) and plate (16). Put the plate on with the flange of the nylon bushing (15) facing down towards the washer. Bolt the plate back onto the base (11). The holes in the plate (16) are elongated to make it possible to adjust the tension of the chain.

Actuator Shaft and Gears 6.3

Adjusting the length of the actuator shaft 6.3.1

After unscrewing the threaded clevis (80) from the actuator shaft (57), the length of the rod has to be readjusted to insure that the paddle is aligned on the centerline when the airvane is in the upright neutral position. Several other situations may also require this adjustment.

The easiest way to adjust the length of the shaft is to look down through the frame from above. Line up the side of the yoke on the pendulum strut (26) with the side of the hinge block at the end of the pendulum shaft (43). You should check the alignment with the airvane upright but set in several different positions around the full circle. Due to the slightly offset rotation of the upper end of the actuator shaft in relation to the bottom end, the final adjustment requires averaging between the correct actuator shaft length at different settings of the airvane.

Changing the actuator shaft bearings and bushing 6.3.4

After extended use, some up and down play in the bearings will develop and the Delrin bearings (54) and bushings (74) for the actuator shaft should be exchanged. The two smaller Delrin bushings in the upper part of the actuator shaft make sure that there is no friction in the rotation of the actuator shaft. A pair of retainer ring pliers makes it easy to remove the (55) retainer rings and replace the bearings.

One washer (75) should be installed on both sides of the #54 bearings to prevent slop. One washer should be on top of the upper bushing (74). Complete the assembly by forcing the retainer rings (55) into their respective grooves. Test pull to make sure that the rings are in the grooves and the assembly is firmly locked in place. A pair of retainer ring pliers makes the



installation of the rings very easy, but, if you do not have one, we suggest that you put a thin thread through one of the holes of the retainer ring to avoid turning it into a UFO.

Disassembling the gears and the pendulum 6.4.1

It is STRONGLY RECOMMENDED that you take the vane gear from the hull when working on or replacing the gears (36 & 37), the pendulum strut (26) and upper pendulum shaft (43), or the bearings and washers for these parts.

Before taking the vane gear off, remove the lower part of the water paddle assembly by taking out the hinge pin (76). When the MONITOR is in a more controlled environment than the stern of the boat, loosen the locknut (56) and unscrew the threaded clevis (80) from the actuator shaft (57). Then, separate the gears by rotating the pinion gear (36) to make its teeth face upwards.

The pinion gear rotates on a 3/8" stainless shaft (33), which also carries the pendulum strut (26). Two setscrews (32) on the pendulum yoke keeps the shaft in place in the frame. Unscrew the socket head screws to allow removal of the shaft.

If you push the shaft (33) out without any further precautions, you will spill the roller bearings (31) inside the pinion gear. When you take the gear apart this may be acceptable, but you need to keep track of all the loose parts.

However, there is a correct way to remove the shaft without spilling bearings and washers (29). This is the only way to put the assembly together again, so you may as well do it right from the start.

In the spare part kit you will find a wooden dowel with the same diameter (3/8") as the pendulum shaft (33). This piece is approximately 4 3/4" long,

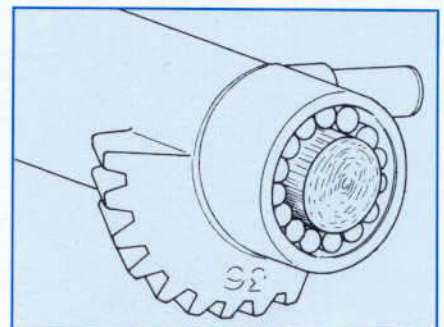

Load the Delrin roller bearings using the wooden dowel in the spare parts kit.

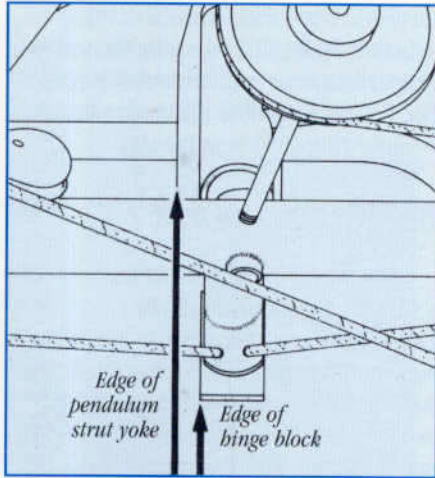

Lock the locknut (56) hard to prevent the shaft from unscrewing from the clevis and changing the adjustment. **Never adjust the actuator shaft without finally checking the proper mesh of the bronze gears,** as described in paragraph 6.3.3.

Adjusting the angle of the pendulum blade 6.3.2

When you adjust the airvane actuator shaft (57) as described in the foregoing, you also make the water paddle (61) line up on the centerline of the boat.

Gear separation – proper mesh of the gears 6.3.3

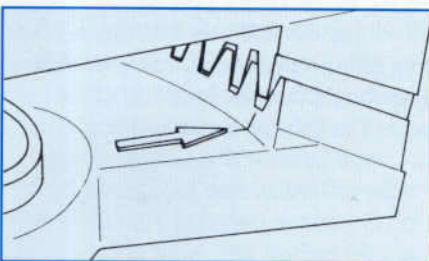

It is important the gears be re-meshed correctly after being unmeshed. The starboard side of the ring gear has an arrow where the first tooth of the pinion gear should land.

Replacing Gears & Pendulum Parts 6.4 (continued)

allowing it to fit between the two ends of the pendulum strut (26). Push the shaft aft, out of the gear and frame, using the shorter wooden piece inserted at the forward end of the frame. Keep one hand on the gear, holding the washers that secure the roller bearings in place against the gear. This also allows you to wiggle the gear a little bit to facilitate pushing the shaft and the short wooden dowel through. At the end of the shaft you should mark the side on which the set screw holes are located. This way you will know how to find the holes when the shaft is put back in the frame. NEVER PULL on either the shorter wooden dowel or the watervane support shaft (33) while the roller bearings are installed. If you do, this will leave a gap between the two which will allow the bearings and washers to spill out. ALWAYS PUSH on one or the other to move them back or forth.

Push the wooden dowel through the frame on the forward end of the pendulum strut until it is just clear of the yoke. You will need a screwdriver or some other instrument to allow you to keep pushing the dowel through. You can feel when it is just clear of the forward end of the yoke, as you will then be able to move the pinion gear (36). The pendulum strut (26) should now hang on the end of the watervane support shaft, which will be more or less flush with the inside of the yoke at its aft end. You are now able to remove the pinion gear, keeping the washers pushed against its ends to keep the rollers captive on the

short wooden dowel.

If the pendulum strut also needs to be removed, just pull the rest of the watervane support shaft out of the aft end of the yoke to let the pendulum strut slip out of the frame.

Remounting the pendulum and pinion gear in the frame 6.4.2

To reinstall the pendulum strut (26) and the ring gear (37), first make sure that the nylon bushings (34) are in place in the frame with their flanges facing the yoke. Hold the yoke in position in the frame between the bushings and insert the shaft (33) from aft with the seating hole for the set screws up. Push the shaft through the aft part of the frame and aft end of the yoke until it is flush with the inside of the yoke. This will keep the pendulum in place while you ready the pinion gear (36).

The pinion gear should now be on the short wooden piece with the roller bearings (31) and washers (29) in place. The stainless steel washers come in different thickness (29.1, 29.2 and 29.3) for fine adjustment of the fore and aft position of the pinion gear. Keep the washers pressed against the end of the pinion gear and insert the assembly inside the yoke. Push the $\frac{3}{4}$ " shaft through the pinion gear, ejecting the short wooden dowel on the front side until the seating hole for the set screws are properly lined up with the holes in the yoke. Lock the shaft in place with the set screws. Mesh the gears and screw the

threaded clevis (80) into the airvane actuator shaft (57), adjusting the rod to proper length as previously described. See 6.3.1. Test pull to make sure that the retainer ring (55) is in the slot.

Replacing the ring gear 6.4.3

It is very unlikely that the ring gear (37) will ever be damaged beyond repair. However, if a new gear has to be installed you should take the pendulum shaft (33) and the pinion gear (36) out of the frame as described above. Take out the machine screw (38.1), which holds the ring gear onto the top of the pivot shaft.

Keep pressure on the large hinge block at the bottom of the shaft to keep the roller bearings (31) of the bottom bearing from escaping between the block and the outside strut. Also keep the top washer pushed towards the strut to prevent rollers (31) of the top bearing from escaping. Install the new ring gear, which requires drilling, on top of the shaft. Take care to leave a slight vertical play of the shaft inside the strut to allow the shaft to move freely without binding. You might consider installing a new black Delrin washer (41) at this time and save the old one for emergency. Stainless steel washers come in a thin and a thick version (42.1 and 42.2) and are used on either side of the upper washer (41) to get the fit just right.

Lay the assembly flat. With the new ring gear properly fitted, the teeth of the gear should face the front side of the yoke. The hole for the hinge pin in the

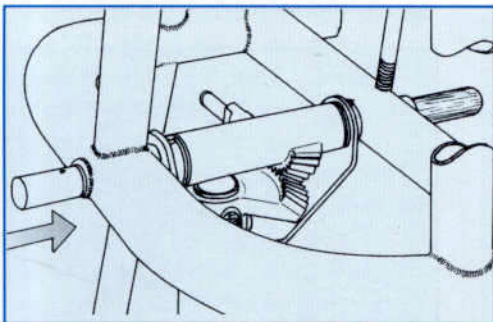

Push dowel out of the shaft. Never pull!

Replacing Gears & Pendulum Parts 6.4 (continued)

hinge block at the bottom of the pivot shaft (43) should face the opposite direction (aft). To adjust the meshing of the ring and pinion gears, it may be necessary to insert a 1/4" washer either at the top, bottom, or both ends of the pendulum strut. The washers come in two sizes (42.1, thin and 42.2, thick).

With the hinge block flush against the lower washer and the ring gear touching the upper washer, the gear should be in the proper position on the shaft. Drill a 1/8" hole for the securing bolt (38.1) – trying, as closely as possible, to line up the existing holes in the watervane pivot shaft (43).

Insert the 1/2" bolt with the head of the bolt on the same side as the horizontal arm of the pinion gear and the airvane actuator shaft (57). (Port side). Put the lock washer (38) and nut (52.2) on the bolt and tighten.

Reassemble the pendulum shaft and pinion gear in the frame as previously described.

Replacing the watervane pivot shaft 6.4.4

To replace the watervane pivot shaft (43), first take the pendulum and pinion gear (36) out of the frame as previously described. Remove the 1/2" bolt from the ring gear (37) and take the gear off the shaft. Slide the shaft out of the strut (26), being careful not to lose the stainless (42) and Delrin (41) washers at the top and the 24 Delrin roller bearings (31) at each end.

Remove the black Delrin washer (41) from the bottom of the shaft, noting which side of the washer is facing the hinge block. This side has been reamed to accommodate the weld between the block and the shaft, and the washer should be installed on the new shaft in the same fashion.

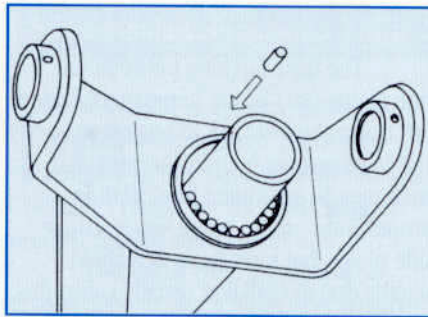

Load the upper and lower bearing cups in the pendulum (26) with 24 roller bearings (31) each. Never use grease in the bearings!

Now insert the shaft in the strut. Turn the shaft with the hinge block up and lift the hinge block away from the strut just enough to load the roller bearings into the cup between the strut and the shaft. When the rollers are in place, push the hinge block flush with the strut to prevent the rollers from escaping. Turn the shaft around, keeping pressure on the hinge block and rest the assembly on the hinge block. Load the upper 24 roller bearings into the upper cup and install the Delrin washer (41) and the stainless washer (42) on top of the pendulum shaft.

Mount the ring gear on the shaft as previously described, taking care to have some vertical play of the shaft inside the strut. Position spacers (42.1 or 42.2) as previously described, and drill a 1/8" hole through the side of the shaft (43), which faces up. Turn the assembly over and drill the other side of the shaft. Insert the 2"-long, round head 1/2" bolt (38.1) through the ring gear and the two holes drilled separately as previously described. The head of the bolt should be on the port side of the gear. Secure with Nyloc nut. Reinstall the complete pendulum in the frame.

Replacing the pendulum strut 6.4.5

To replace the pendulum strut (26) involves practically identical moves as in replacing the watervane pivot shaft (43), except new holes are not required in the ring gear (37) or shaft.

The welding process might have caused each yoke to vary slightly and it may be necessary to slightly bend the ends of the yoke to get a good fit for it inside the frame without binding or slop. It may be necessary to adjust the horizontal distance of the yoke opening with stainless steel washers. There should be no binding or slop in the fit of the pinion gear (36) between the yoke ends.

The Hinge and Latch Assembly 6.5

Latch adjustment 6.5.1

Severe damage may make it necessary to replace the hinge (44), including the safety tube (67) and the latch (47). In the factory each latch is matched to the hinge block on the watervane pivot shaft (43). To get a new latch to engage and disengage properly you may have to work on it a little bit. We call it "massage."

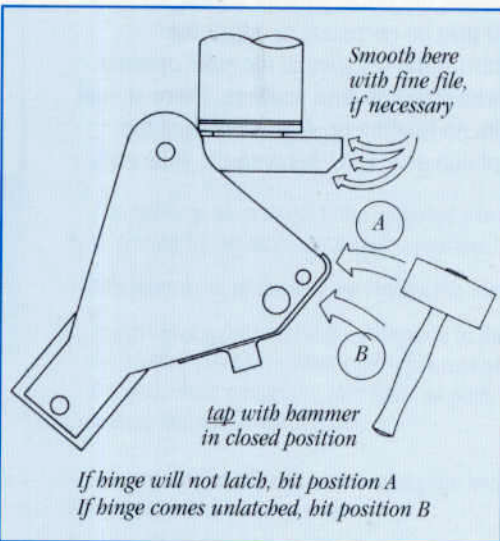

The lip of the latch (47) should extend $\frac{3}{16}$ "– $\frac{1}{4}$ " over the edge of the hinge block when the water paddle is engaged in the "down" position. If the lip goes further in (over the hinge block), the latch will not engage easily – or at all. It will hit the bottom of the hinge block too far in and will not slide up over the beveled bottom edge of the hinge block. This effect should be prevented by a small stop screw (32), which restricts the movement of the latch.

Problems getting the latch to engage properly can usually be fixed by hitting lightly with a hammer on the forward face. The stop screw should then bend slightly and permit the lip of the latch to extend a bit further over the hinge block. Sometimes it might help to file the bottom edge of the hinge block a bit further to help the latch to engage smoothly.

Hinge adjustment 6.5.2

The latch sticking between the side plates (44) of the hinge mechanism will cause the gear not to engage properly and to disengage by itself because the latch may be restricted from getting a proper hold on the hinge block. Hinge side plates that have been deformed slightly due to collision usually cause this. Usually it is easy to see where the latch is binding. Use a flat punch to "massage" the hinge plates so that the latch is freed.

Replacing the Safety Tube 6.6

If an overload or collision occurs, the safety tube (67) is designed to buckle. We like to point out that it is very unlikely that the safety tube will fail. Most boats that circumnavigate do not have a single safety tube failure! If you have repeated failures you should contact the factory since this indicates that something is wrong. For certain boats we also use safety tubes with thicker wall thickness, which might be needed. To replace the safety tube, you should take the entire hinge, safety tube and water paddle onboard. Remove the hinge pin (76) and use the safety line, which is attached between the water paddle and the lower bolt on the safety tube. Remove the two bolts that are holding the safety tube. Take out the old safety tube and replace it. Secure it with the bolts.

Making Your Own Airvane 6.7

If you have lost both your airvanes and are far away from civilization, you can always make your own. (We first suggest you read paragraph 2.2 "The Airvane," in this Manual.) Then try to find some decent plywood and cut out a vane with the help of the measurements illustrated here. We suggest that you make the airvane as large as possible. It is **extremely** important to get the weight right. You will probably find that your airvane is top heavy and then it will not work. If you make the airvane shorter you can get the weight right but you will also make it less effective in light air. We suggest that you experiment with a hole saw on a larger airvane and cut out some material at the top. You can then cover the holes with lightweight regular shipping tape (like what is used on cardboard boxes). The airvane should always return to the upright position on a windless day.

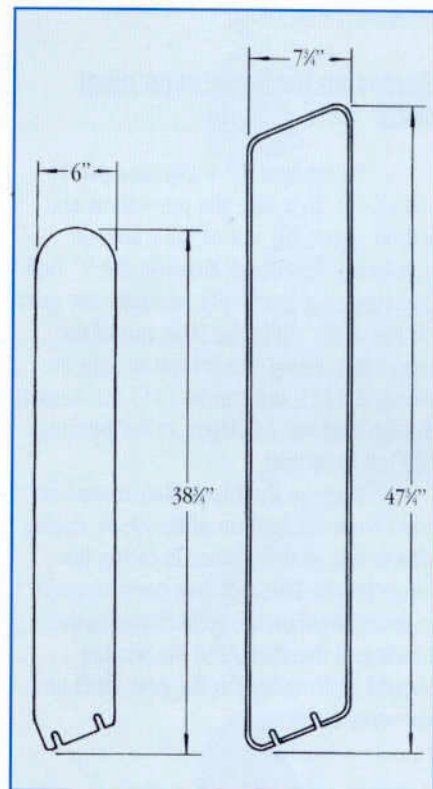

Standard Airvane vs. Light Airvane (60% larger)

Instructions 7.1

We sincerely hope that you never have to use it the MRUD. If you do, it means you've lost your boat's main rudder. A boat without a rudder is a serious matter and these instructions are intended to make sure that you MRUD is understood and used properly in the event of rudder failure on your boat.

We **strongly recommend** that you fit MRUD to your MONITOR before you leave on your next long cruise and even use it on a short test sail. If you practice putting MRUD on in port, it will be much easier to repeat the installation at sea should the installation become necessary, often under difficult conditions at sea.

The MONITOR is a servo-pendulum gear with a small servo-paddle. When you transform the MONITOR to a much larger, rigged emergency rudder, the loads are greatly increased and you should make sure that your MONITOR mount accounts for this greater load:

- Backing plates. The MONITOR mounting brackets do not normally need backing plates. If your boat is a lightweight core construction you might need them. If in doubt, consult the factory. MRUD puts a bigger load on than normal MONITOR sailing. You have to decide if you should add backing plates when you purchase the MRUD.

- Strut guard. Since 1991 all MONITOR units built have strut guards (831). This protective "bumper" goes behind the pendulum and connects the legs of the main frame with each other. It also makes the main frame a strong structure. Older MONITORS do not have a strut guard, but it can be retrofitted. With the use of the MRUD, the MONITOR has to have a strut guard because it is where the wedge that holds and supports the pendulum is placed.

- Test the fit of the wedge. Place the wedge between the strut guard and the pendulum. The wedge fit is somewhat loose of the frame in an emergency location of the strut guard and it might be necessary to tap the wedge in place. If your wedge is too tight, we suggest that you sandpaper the wedge along the top fit to make it make it tight by adding some duct tape to make it more snug. Make sure that the wedge is secured with the all lines that are attached to the wedge. Electrical wire straps can be very useful when positioning the wedge to keep it in place while attaching the necessary lines to mobilize the pendulum strut.

- Through bolt clamp tubes. Since 1998 the lower mounting tubes are attached to the frame with end fittings that are through bolted. Older MONITORS used clamp tubes that squeezed the mounting tubes. To be absolutely sure that the tubes cannot escape from the old style clamp tubes, both fittings should be through bolted with stainless steel bolts.

Diagonals. The MONITOR frame is attached to the hull in four places. With longer mounting tubes we sometimes add some side diagonal tubes which make the installation tremendously strong. With the use of MRUD some installations should add diagonals. Consult the MONITOR factory for advice.

THIS PAGE IS OBSOLETE - MRUD BROCHURE AT END OF FILE

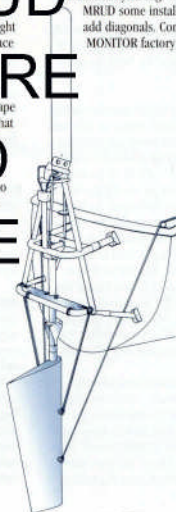

Mounting and Operation of the MRUD at Sea 7.2

Mounting the MRUD 7.2.1

The mounting process can be dangerous, particularly in rough seas. Work carefully, following these steps:

- (1) Heave to with the boat and try to avoid forward movement. Wear your safety harness. If you have a good one we suggest that you wait for good weather and have a good night's sleep before starting.
- (2) Disconnect MONITOR pendulum lines from the tiller or wheel adapter and **lock the pendulum in the middle** by clearing the lines.
- (3) Place the wedge between the pendulum and the strut guard. Secure it with lines that are attached to the wedges.
- (4) Remove the servo-paddle assembly (61) by removing the cotter ring (76.2) and the hinge pin (76). Store the servo assembly.
- (5) Attach the MRUD assembly to the MONITOR. This can be done in different ways and it should have been practiced at the dock. One way is to hold the paddle upside down with the help of the attached lines when you put the special tapered hinge pin through the hole in the hinge block. The pin is attached to the hinge with a safety line. When the pin is in place, the cotter ring is used to lock the hinge pin in place. Another method to attach MRUD is to let it float behind the MONITOR while the hinge pin is put in place. Boat type, weather and the agility of the skipper will help you decide. Use at least one Spectra line as a safety line.
- (6) The next step is to secure the "upside down lowers." These are the Spectra lines that are attached to the upper eyebolts of the MRUD. Once again we are using a "MONITOR Special" knot. (See paragraph 3.5.3.) The lines have a bowline with a tail close to the rudder

blade. This tail line should go around the corner of the strut guard where it is welded to the leg of the frame. The line should then go down to the bowline and then up to the strut guard again. By running the line back and forth you have now a very simple and practical block and tackle purchase system. The Spectra will stretch very little and will be an easy system to make the lines tight. Do the same thing with the "upside down" "upside down lower" line.

(7) The lines that are attached to the lower eyebolts of the MRUD are called "upside down lowers" and where you should attach them will depend on the boat. By leading them forward to the corners of the aft end of the boat, you support the MRUD in two places. Use the side pressure hull to go against the water rushing past it. You can lead the lines to a temporary block and then to a winch. You have now secured the pendulum with the wedges and the lines as a support for the rudder in the same way your mast is supported with uppers and lowers - only this "mast" is upside down.

Operating with the MRUD 7.2.2

We suggest that you inspect the lines frequently for chafe and even consider adding an extra safety "shroud" or side support line. You probably have to experiment with the tension of the lines. They are not tight enough to be a problem turning the rudder.

Your MONITOR now has a rigid spade rudder ready to steer your boat. Of course you need to balance your boat very carefully and probably reduce sails somewhat. Compared to your boat's rudder you may feel that the MRUD is too small to control your boat. However, we have purposely kept it this way (will not break easily, easy to store, easier to install at sea, etc.). With a normal boat there are very small corrections with the rudder unless you carry too much sail or have ignored balancing the sail plan.

We also decided to go through the MONITOR gear set to steer with the MRUD. It is not possible to turn the rudder very sharply but we feel that this will save the MRUD from overload which could occur if you could turn it too much. The large size of the boat's main rudder is necessary for maneuverability, which is needed when you dock the boat in crowded waters. In the open ocean you can make slow corrections. At your destination you can anchor or get help for the last few miles if you feel that you cannot maneuver in tight corners.

Our goal is to get a boat without a rudder back to port. MRUD was tested in AROUND ALONE 1998 when Robin Davis sailed his 50-footer 2000 miles to Cape Town after the boat lost the main rudder.

You can now steer by three different methods.

- 1. By hand.** Grab the counterweight and move it. You are now steering by hand. You can rig up lines to the counterweight to steer from any position on the boat.
- 2. With the regular MONITOR airvane.** Your MONITOR will now work as an auxiliary rudder self-steering windvane. The Spectra tension lines provide some friction. You might find that the performance improves if you ease the Spectra lines just a little bit - if conditions permit.
- 3. With a small autopilot.** A small tiller pilot can be rigged up to the counterweight. The tiller pilot will steer a magnetic compass course.

Warranty 8.1

SCANMAR INTERNATIONAL is the manufacturer of the MONITOR windvane and the MRUD. A card showing the limited warranty has been included with each new unit in the pocket of the back cover of this manual. Please contact us if this card was not included with your unit. The warranty set forth in the express limited warranty card is the exclusive warranty of the product and is in lieu of any other warranty whether implied or statutory (including warranties of merchantability and fitness for a particular purpose). The remedies available to the buyer are limited to the remedies described in the express limited warranty card.

SCANMAR INTERNATIONAL reserves the right to change the design of our products at any time and without notice.

The attached Warranty Registration Card should be returned to the manufacturer together with requested photographs of the installation.

Warranty Photographs 8.2

We like to point out that our request for photos is **EXTREMELY IMPORTANT**. With your photos we should be able to check that your installation at least looks OK. If we see anything wrong we will be able to advise you.

Please take one photo of the vane gear from behind and one photo from the side. The airvane should be mounted and the watervane should be down and latched so that the stationary degree of immersion of the water paddle can be clearly seen. Take another shot showing the installation of the pendulum sheet lines to the wheel or tiller. A clear view of the placement of the blocks is also desirable. More photos are always more helpful than too few so please feel at liberty to send us more than three.

There are some very sound reasons behind our request for photos. We have had clients report back to us that the installation went like a dream and that the unit was installed exactly per our instructions only to find when we have seen the actual boat or photos, that the unit had not been correctly installed at all. Many of our customers undertake long journeys that may take them all the way around the world. If we get a call from a more remote part of the world telling us of a problem, it can sometimes be impossible to fathom what is going on without these pictures. Having pictures on file saves everyone concerned a great deal of time and frustration. Our goal is to be able to assist you for many years after the MONITOR was sold to you. Your photos will help us to help you. We look forward to receiving your installation photos.

A word of caution 8.3

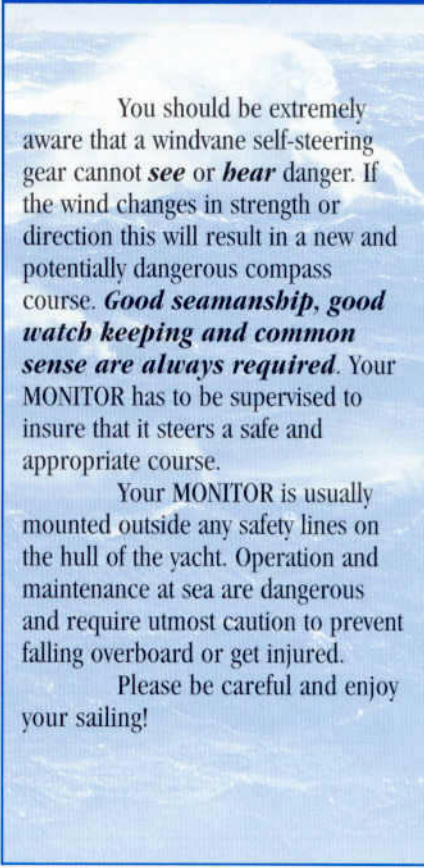

You should be extremely aware that a windvane self-steering gear cannot **see** or **bear** danger. If the wind changes in strength or direction this will result in a new and potentially dangerous compass course. **Good seamanship, good watch keeping and common sense are always required.** Your MONITOR has to be supervised to insure that it steers a safe and appropriate course.

Your MONITOR is usually mounted outside any safety lines on the hull of the yacht. Operation and maintenance at sea are dangerous and require utmost caution to prevent falling overboard or get injured.

Please be careful and enjoy your sailing!



Valiant 40

Pretorian 35

Wilderness 40

Ingrid 38

Tartan 40

Allegro 33

Hallberg-Rassy 42

Baltic 38

Roger Martin BOC 50

Alden 50

Hans Christian 33

Tayana 37

Santa Cruz 50

ASMA

Tayana 52

Beneteau Oceanis 35

Kaskelot

Freedom 35

British Steel 67

Ericson 36 Cruising

CSY 44

Tasbiba 36

Down East 32



SCANMAR INTERNATIONAL

Manufacturers of Marine Self-Steering

432 South 1st Street, Point Richmond, CA 94804 USA

Tel: 510 215-2010 • Fax: 510 215-5005 • email: scanmar@selfsteer.com • www.selfsteer.com • Call Toll Free: 1-888 WINDVANE (946-3826)

© 1999 Scanmar International . All rights reserved

MRUD

MONITOR EMERGENCY RUDDER

In the 1994-95 BOC (Single-handed Around the World Race) seven out of eleven boats had MONITOR windvanes. In the 1998-99 Around Alone (same race, different sponsor) the five boats that used windvanes all used the MONITOR windvane. Again, no other windvane was used in the race.

The MONITOR'S servo-pendulum system had once again been proven the best self steering principle.

Since the BOC 1986-87 there has not been a single auxiliary rudder self steering system in the race.

It was our goal to make an emergency rudder that would work for the BOC and Around Alone boats. It has been tested in real conditions for 2000 NM on such a boat. That should satisfy the requirements for normal cruising boats.

In Heavy Weather Sailing, by Adlard Coles

The author remarks, "Breakages of rudders are almost as common as breakages of masts."

MONITOR, THE SELF STEERING SOLUTION

There are many different systems of windvane self-steering. Trim tab, auxiliary rudder and servo pendulum systems are just a few. The development of the servo-pendulum principle represented a breakthrough in windvane self-steering. As the boat moves faster with stronger winds, the power of the servo oar increases and this gives ample power to turn the boat's own large rudder. The MONITOR steering system is powerful and has positive yaw dampening which makes it possible to steer straight in difficult downwind conditions. The more it blows, the better the MONITOR likes it. Consensus of opinion is that the servo-pendulum principle is the best method of self steering for most boats.

MRUD, THE EMERGENCY RUDDER

Our challenge was to be able to convert the MONITOR aboard a 50 foot BOC boat, in the roaring forties, into a true emergency rudder. We knew that the strength required for survival in these conditions would guarantee a more than adequate back up system for cruisers having the misfortune to lose their boat's rudder. MRUD has been designed to meet the following criteria:

- Strong and dependable
- Reasonably easy to install at sea
- Easy to store on board
- Affordable

MRUD offers a unique solution to a serious problem.

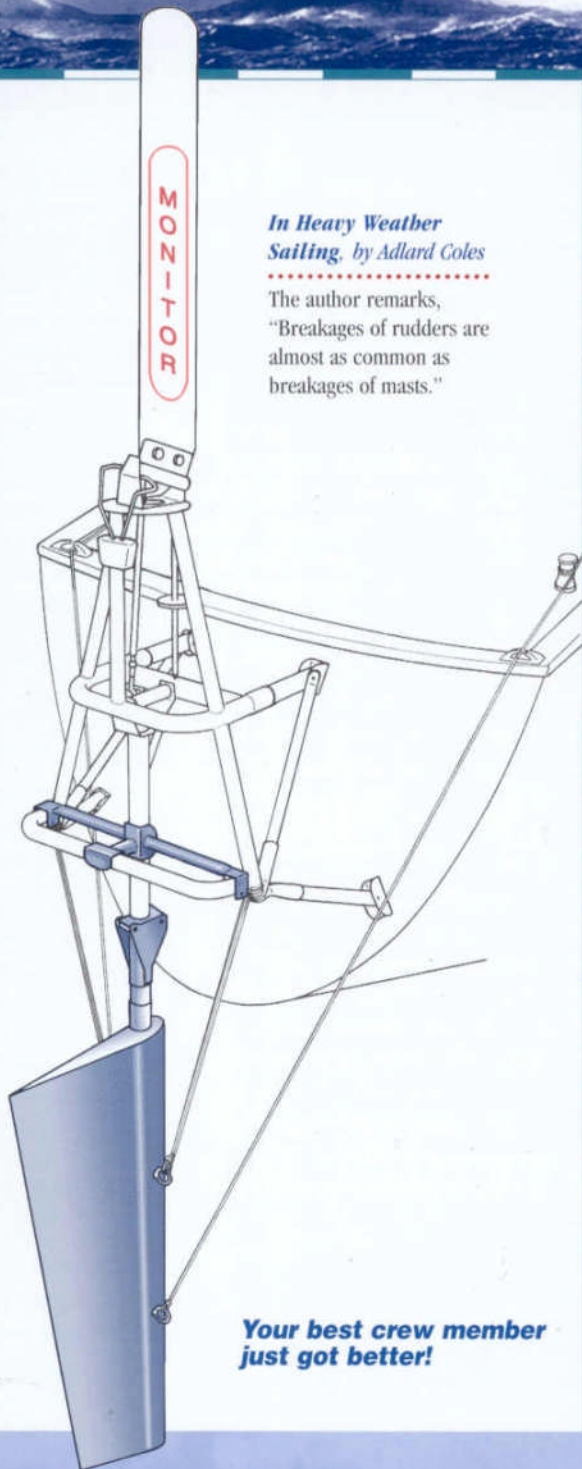

**Your best crew member
just got better!**

THE MONITOR EMERGENCY RUDDER CONVERSION KIT

Finally a solution to the nightmare of losing your boat's main rudder.

The MONITOR has survived the toughest oceans in the world, sailed through seas and weather which would qualify as a cruiser's nightmare and kept on steering.



Many attempts have been made to make individual emergency rudders. The majority require very expensive custom engineering and manufacturing.

Excessive weight and size make these custom rudders difficult to store and install at sea, and, even so most have questionable performance and reliability.

The beauty of the MONITOR MRUD system is that it uses the regular MONITOR servo pendulum system which is converted to an emergency rudder. The standard MONITOR mounting system is extremely strong because it has four stainless steel mounting tubes that are spread apart to distribute the load over a larger area. If the mounting tubes are long, diagonal tubes are added for additional strength.

Half the emergency rudder problem is the method of attachment. With the MONITOR in place the attachment system is already there! The MONITOR mounting system is strong enough to support a large, rigid rudder.

The challenge is to make an emergency rudder that can handle side loads, which occur in rough weather. The new stainless steel wedge supports the MONITOR pendulum shaft from side and forward loads that occur in broaches as well as from water rushing by. The MRUD also has two sets of eyebolts on the rudder blade itself. Low stretch spectra support lines are attached to the eyebolts and lead to suitable attachment points on the MONITOR frame and the boat. They often lead to winches by temporary blocks.

The MONITOR MRUD is highly efficient because it has a high lift NACA profile and because it is located behind the boat. The size of the emergency rudder can therefore be smaller making it more practical to store and to mount, yet still large enough to steer a 50 foot boat.

The MONITOR principle works on the boat's own rudder rather than using an auxiliary rudder/trimtab system like our own *auto-helm* windvane. Such systems can be used as emergency rudders, but they are not in general the best principle for normal self steering.

If the main reason for buying an auxiliary rudder windvane is to have an emergency rudder you should look into other options. It would almost be like sailing around with your life raft inflated- just in case the boat would sink.

If a boat experiences weather that is bad enough to break the boat's main rudder those conditions are probably bad enough to do severe damage to an auxiliary rudder type of self steering. The damaged main rudder can also damage the auxiliary rudder. The servo pendulum gear does not have this problem. It has the ability to move to the side, out of the way, and it has an easily replaced safety tube in case of an overload situation.

We prefer to use the best principle for normal self steering, (servo pendulum) and in the unlikely situation that the boat's own rudder is broken, the strong, stainless steel MRUD can be mounted at sea and steer the boat to safety.

You can steer by hand by moving the counterweight from left to right, by using the regular MONITOR airvane or by hooking up a small inexpensive autopilot to the MONITOR counterweight.

A pin with a cotter ring holds the servo paddle which is removed and replaced by the much larger emergency rudder assembly. The stainless steel rudder is foam filled for strength and flotation. The hinge has a special tapered hinge pin to make it easier to mount at sea. The pendulum is locked and supported by a stainless steel wedge between the pendulum and the strutguard. Spectra lines add extra support for front and side loads, just the way a mast is stayed.

The MRUD is similar to your life raft. We hope that you never have to use it, but if you do it will be the most important piece of gear on board.

Can you afford to be without it?

The BOC and Around Alone are unparalleled as a test of equipment. These boats not only round Cape Horn, they stay in the Southern Ocean lower latitudes for several months of brutal weather and towering seas.

MRUD was developed with these conditions in mind.

PREPARATIONS



Around Alone - Leg 2 en route towards New Zealand

A boat without a rudder is a serious matter and these instructions are intended to make sure that your MRUD is understood and used properly in the event of rudder failure on your boat.

We strongly recommend that you fit MRUD to your MONITOR before you leave on your next long cruise and even use it on a short test sail. Should the installation become necessary, you may be in rough seas. If you practice putting MRUD on in port, it will be much easier to repeat the installation later at sea.

Your MRUD assembly contains:

- Complete hinge assembly
- Safety tube and spare
- Special tapered hinge pin
- Stainless steel "wedge" with bolts and clevis pins
- Upper Spectra support lines
- Lower Spectra support lines
- Foam filled Stainless steel Emergency Rudder
- Bolts for clamp tubes
- Storage bag with attachments for hoisting

When you transform the MONITOR to a much larger, rigid emergency rudder the loads are greatly increased and you should make sure that your MONITOR is mounted as follows:

• Backing Plates

The MONITOR mounting brackets do not normally need backing plates. If your boat is a light weight core construction you might need them. If in doubt consult the factory.

• Strutguard

Since 1991 all MONITOR units built have strutguards. This protective "bumper" goes behind the pendulum and connects the legs of the main frame with each other. It also makes the main frame a lot stronger. Older MONITORS did not have the strutguard but it can be retrofitted. With the use of MRUD the MONITOR has to have a strutguard because this is where the stainless wedge that holds and supports the pendulum is placed.

• Test the fit of the wedge

Place the stainless steel wedge between the strutguard and the pendulum. The horizontal distance have some variation and after the wedge is in place the telescoping tubes have to be drilled and bolted to fit each individual MONITOR. Use the starter hole, drill and through bolt with the supplied bolts. You might have to "massage" the wedge a little to make it fit easily. We suggest that you secure all the pieces with safety lines when working over water.

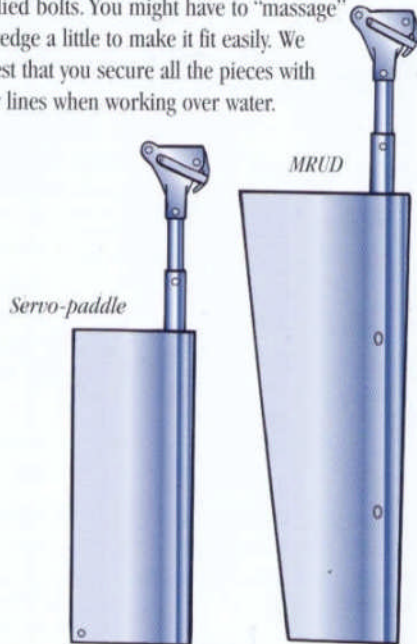

• Through bolt Clamp Tubes*

The lower mounting tubes are attached to the frame with clamp tubes that are attached to the bottom of the frame legs. To be absolutely sure that the tubes cannot escape from the clamp tube both fittings should be through bolted with small stainless steel bolts (included).

* Not applicable after serial # 56870298.

• Diagonals

The MONITOR frame is attached to the hull in four places. With longer mounting tubes we sometimes add same side diagonal tubes which make the installation tremendously strong. With the use of MRUD some installations should add diagonals. Consult the MONITOR factory for advice.

Leg 1 is over, South Carolina arrived in Cape Town without a rudder, and what will be documented is that the 2,300 miles I sailed without a rudder are, without a doubt, the most difficult and demanding 2,300 miles I have ever sailed - or ever want to sail.

It was a far more difficult proposition than my 2,500 mile jury rig sail in the Southern Ocean around Cape Horn to the Falkland Islands after my dimasting in the 1994-95 BOC race.

MRUD was a very significant part of my emergency rudder system, and without it - I think it would have been difficult for me to make it into Cape Town as quickly as I did.

I can only strongly recommend that all MONITOR users going offshore take the MRUD system as their emergency steering system. It will, without any doubt, get them into port should the ultimate mishap of a broken rudder occur. I would strongly recommend they try it out beforehand.

The MONITOR has served me well during Leg 1 as it always has during two BOC's on Cornwall.

*Thanks, Best Regards
Robin Davie*

Mounting and operation of the MRUD at sea

If possible, wait for good weather and plan all procedures in advance.

1. Heave to with the boat and try to avoid forward movement. Wear your safety harness.
2. Disconnect MONITOR pendulum lines from the tiller or wheel adapter and lock the pendulum in the middle by taking the lines to a cleat.
3. Place the wedge between the pendulum and the strutguard. Secure the wedge by attaching it to the strutguard with clevis pins. Use safety lines.
4. Remove the servo paddle assembly by removing the cotter ring and the hinge pin. Store the servo assembly.
5. Attach MRUD assembly to MONITOR. This can be done in different ways and it should have been practiced at the dock. One way is to hold the paddle upside down with the help of the attached lines when you put the special tapered hinge pin through the hole in the hinge block. The pin is attached to the hinge with a safety line. When the pin is in place the cotter ring is used to keep the hinge pin in place. Another method to attach MRUD is to let it float behind the MONITOR while the hinge pin is put in place. Use at least one spectra line as a safety line. We have also seen a boson chair being used to secure the person doing the work safely. Consider using preventer lines to stop the swing of the boson chair.
6. Next step is to secure the upper spectra lines which are attached to the eye bolts. The lines should go around the corner of the strutguard where it is welded to the leg of the frame. The line should then go down to the eye bolt and then up to the strutguard again. By running the line back and forth you have now a very simple and practical "block and tackle" purchase system. Lock the lines with a half hitch. The upper spectra lines will stretch very little and you have an easy system to make the lines tight. Do the same thing with the opposite upper line.

The lower lines should be lead to a cleat or a winch on deck. You have now secured the pendulum with the wedge and the spectra lines are supporting the rudder the same way your mast is supported with uppers and

lowers-only this "mast" is upside down. Check for chaffing of the spectra lines after use and add or replace lines as necessary.

Do not over tighten the support lines. Experiment with the tension. If the lines are too tight, you will have problems turning the MRUD.

Your MONITOR now has a very rigid and strong spade rudder ready to steer your boat. Of course you need to balance your boat carefully and possibly reduce sails. Compared to your boat's rudder you may feel that the MRUD is too small to control your boat. However, we have purposely kept it this way (will not break, easy to store, easier to install, etc.). With a normal boat there are very small corrections with the rudder unless you carry too much sail or have ignored balancing the sail plan. The large size of the boat's main rudder is necessary for maneuverability which is needed when you dock the boat or are on a race course. With MRUD in the open ocean and a course to steer you can make slow corrections. At your destination you can anchor or get help for the last few miles if you feel that you cannot maneuver in tight corners.

You can now steer by three different methods.

1 By hand: Grab the counterweight and move it. You are now steering by hand. You can rig up lines to the counterweight and steer from any position on the boat.

2 With Light Air MONITOR airvane: Your MONITOR will now work as an auxiliary rudder self-steering windvane. The spectra tension lines provide some friction. You might find that the performance improves if you ease the spectra lines just a little bit if conditions permit.

3 With a small autopilot: A small tiller pilot can be rigged up to the counter weight. The tiller pilot will steer a magnetic compass course. (See Monitor Manual 4.6)

Manufactured and sold factory direct by

SCANMAR
INTERNATIONAL

432 South 1st Street,
Pt. Richmond, CA 94804 USA

Tel: 510 215-2010 • Fax: 510 215-5005

Toll Free: 888-WINDVANE (946-3826)

email: scanmar@selfsteer.com • www.selfsteer.com